

TRIO

APRIL | 2022



Cowboy **CHRICLE**



Finishing a quick pistol string, Pinky MacRae (SASS #93559) grabs her '73 to wrap up a fast stage at the 26th Annual Chorro Valley ShootOut — the 2021 SASS Western Regional Championship.



Wild West Mercantile

7302 E. Main Street Suite #7 Mesa, AZ 85207

www.wildwestmercantile.com 800-596-0444

The Official Clothier Of SASS



Cowboy Chronicle Savings

10% OFF

Use coupon code **COWBOY10** at check out and get 10% off your merchandise subtotal.

Code good April 01, 2022 through June 30, 2022

Discount can not be combined with other discount codes or prize certificates
Discount not applicable on prior purchase. Ladies Millinery & Gift Certificates Excluded.
Some in store restrictions apply.

Visit Our Store Location
in Mesa Arizona

We are located in East Mesa

Main Street between Power Rd & Sossamon Rd
on the north side of the street in the
Sun Valley Plaza

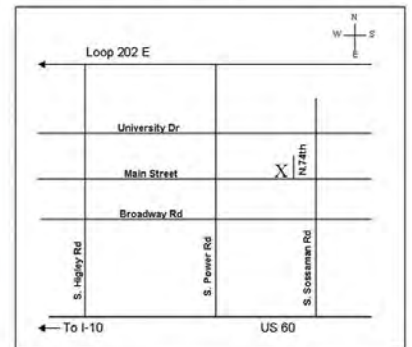

Need A Gift Idea?

Give Them A Buckaroo Buck Gift Certificate!



**MERCANTILE
Store Hours**

Monday-Saturday 10am-5pm
Closed Sunday

www.wildwestmercantile.com

Toll Free: 1-800-596-0444
info@wwmerc.com



PUBLISHED BY THE WILD BUNCH

THE COWBOY CHRONICLE, APRIL 2022
VOL. 2 #26

SINGLE ACTION SHOOTING SOCIETY®
PO Box 960
102 E. ROCHESTER STREET
AKRON, IN 46910
877-411-SASS • FAX 877-770-8687
WWW.SASSNET.COM
© 2022 – ALL RIGHTS RESERVED

EDITORIAL STAFF

EDITOR-IN-CHIEF

Skinny

MANAGING EDITOR

Misty Moonshine

EDITORS EMERITUS

Tex & Cat Ballou

ADVERTISING MANAGER

Square Deal Jim

410-531-5456 | chronicleads@sassnet.com

GRAPHIC DESIGN

Mac Daddy

SASS® Trademarks

SASS®, Single Action Shooting Society®, The Cowboy Chronicle™, Cowboy Action Shooting™, END OF TRAIL™, The World Championship of Cowboy Action Shooting™, Founders Ranch™, SASS Western Heritage Museum & Cowboy Action Shooting Hall Of Fame™, SASS Scholarship Foundation™, Wild Bunch™, Wild Bunch Action Shooting™ — are all trademarks of The Single Action Shooting Society®. Any use or reproduction of these marks without the express written permission of SASS® is strictly prohibited.

The Cowboy Chronicle (ISSN 15399877) is published quarterly by the Single Action Shooting Society®, 215 Cowboy Way, Edgewood NM 80715 for the benefit of its members. Periodicals Postage paid at Plattsburgh, NY and additional mailing offices (USPS #032 Permit #20591).

POSTMASTER: Send address changes to The Cowboy Chronicle, PO Box 960, 102 E. Rochester, IN 46910

DISCLAIMER: The Single Action Shooting Society does not guarantee, warranty, or endorse any product or service advertised in this publication. The publisher also does not guarantee the safety or effectiveness of any product or service illustrated. The distribution of some products/services may be illegal in some areas, and we do not assume responsibility thereof. State and local laws must be investigated by the purchaser prior to purchase or use of products/services.

WARNING: Neither the author nor The Cowboy Chronicle can accept any responsibility for accidents or differing results obtained using reloading data. Variations in handloading techniques, components, and firearms will make results vary. Have a component gunsmith check your firearms before firing.

CONTENTS

3-5

COVER FEATURE

Chorro Valley ShootOut 2021 — Western Regional

6

EDITORIALS

Skinny's Soapbox

7-9

NEWS

Honoring American Veterans Afield 2021
Henry Repeating Arms Raises More Than \$40,000 for Indiana Girl's Cancer Treatments Shoot for a Cure 2021

10-20

ANNUAL MATCHES

Canadian National Championship 2021
Defend the Fort 2021
Mason Dixon Stampede 2021
The Whoopin' 2021

22-28

GUNS & GEAR

Dispatches From Camp Baylor — Colt Faro Leather
Black Powder 101 Part I

30-34

HISTORY

Maximilian's Not-So-Excellent Adventure in Mexico

35

POEMS

Alone by the Campfire
The Outlaw

36-41

PRODUCT REVIEW

Kirst Konverter Part IV

42

TRAILMARKERS

The Apache Kid — A Happy Trail Marker

43-55

WILD BUNCH

Arizona State Championship 2021
California State Championship 2021
Missouri State Championship 2021
Texas State Championship 2021

56-64

COMIC BOOK CORNER

Blazing West #1 — Buffalo Belle

68-78

SASS AFFILIATED CLUB LISTINGS

2020 Monthly and Annual Shooting Schedules

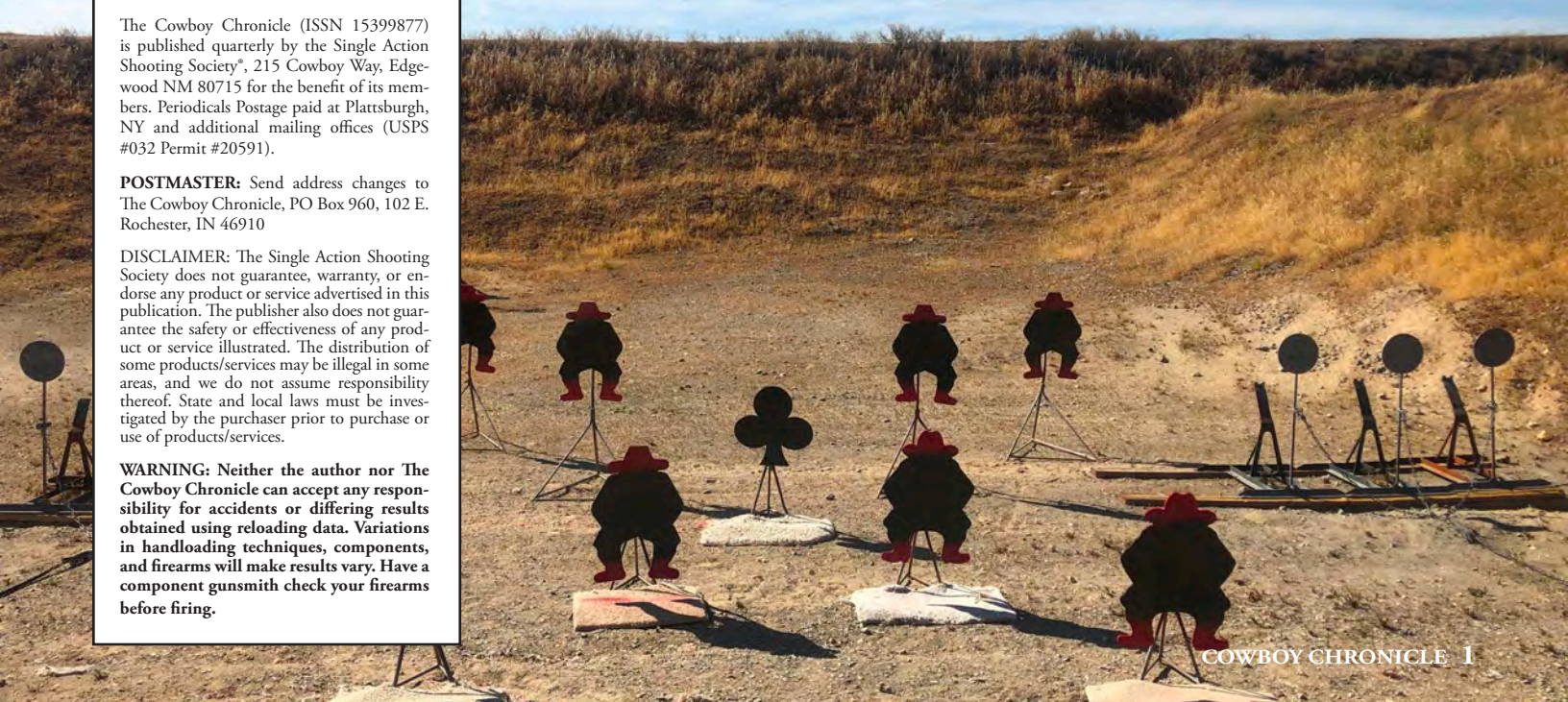

THE SINGLE ACTION SHOOTING SOCIETY & CVR PRESENT

**THE 27th ANNUAL CHORRO VALLEY SHOOT-OUT
2022 SASS WESTERN REGIONAL CHAMPIONSHIP
AUGUST 10th - 14th, 2022**



**Located in the beautiful township of
Chorro Valley, San Luis Obispo, California**

- *12-Stage Main Match*
- *Side Matches Galore*
- *Warm-Up Mini Matches*
- *Age-Based Speed Events*
 - *Last Chance Saloon*
- *5-Star Saturday Night Dinner*
 - *Monte Mills and his Lucky Horseshoe Band*
 - *Cowboy Church*
 - *Vendors Galore*
- *Long Range*
- *Cowboy & Cowgirl Trap*
- *Plainsman Match*
- *Wild Bunch Match*
- *Men's and Ladies Top 16 Shoot-off*
- *Team Shoot*
- *Costume Contest*
- *ROI & ROII Classes*
- *Texas Hold'em Tournament*

**For On-Line Shooter & Camping Registration or
PDF Applications & Match Schedule Visit:
www.chorrovalleyregulators.com**

**Questions or Match Information contact Sinful at:
michaelgarripee@yahoo.com**

COVER FEATURE



JUST NINE MILES FROM THE PACIFIC OCEAN, THE CHORRO VALLEY REGULATORS' RANGE SITS BETWEEN THE SEVEN ANCIENT VOLCANIC MOUNTAIN PEAKS, KNOWN AS THE SEVEN SISTERS, TO THE WEST AND THE SANTA LUCIA MOUNTAIN RANGE TO THE EAST (SHOWN HERE BEHIND OUR VENDORS); AN AREA THAT IS CONSIDERED ONE OF CALIFORNIA'S BEST CLIMATES.

CHORRO VALLEY SHOOTOUT 2021 SASS WESTERN REGIONAL

BY ROGER RAPID, SASS #96080
PHOTOS BY DOUBLESHOT DARLIN,
SASS #70752

Oh, give me a home, where the buffalo roam, where the deer and the antelope play... an old and friendly lament of the once open and wild west. When you get about as far west as you can go and still be standing on land, we still have buffalo, there are plenty of deer, and over the past 15 years or so, herds of antelope have flourished in the great California plains.

California is also the home of The Chorro Valley Regulators — host of the annual SASS Western Regional/Chorro Valley ShootOut every August. Located just nine miles from the Pacific Ocean, as the crow flies, the weather at the range is



JOSHUA THE KID PROVES THAT US OLD FOLKS CAN'T KEEP UP AS HE HEADS FOR THE SHOTGUN WINDOW WITH HUD (SASS #16409) AND TIMER TRYING TO STAY CLOSE BEHIND.

as good as it gets with cool mornings and moderate afternoons.

“We were excited to see so many shooters getting back into our sport this past year after a brief hiatus from matches,” said Sinful (SASS #73672), CVR’s Match Co-Director. “We had almost 270 shooters register for the Western Regional, which was better attendance than our previous Regional.”

Ruthless Rodg (SASS #100071), our Vendor Co-Coordinator, said, “In addition to a good turnout of shooters, there were 19 vendors this year, and one even showed up with a bunch of primers. Boy, he sure was busy for a while! I was happy to see the vendors were all pretty busy. That told me they had the kind of goods our attendees were looking for.”

With a focus of keeping the posse size comfortable and efficient, we organized 18 posses that averaged about 15 to 16 shooters each. Just the right number of shooters to keep folks moving while not over-taxing any of the posse mem-



DEFTLY DROPPING TWO INTO HIS SIDE-BY-SIDE, JOHN RINGO (SASS #98549) READIES FOR FOUR LIGHTNING-QUICK SHOTGUN KNOCKDOWNS.

bers who were spotting, picking shells, or working the loading and unloading tables.

The 12 stages, crafted by Sinful, featured everything from stand-and-deliver to darn challenging scenarios with targets positioned carefully to be somewhere between SASS-legal and not-in-your-face. We had 15 clean shooters, so at least 15 cowpokes found all the targets on their way through the match.

Side matches included speed pistol, speed rifle, and speed shotgun. There was also Cowboy trap, and a Long Range event with targets at 100, 125, and 400 yards.

A highlight early in the weekend is our three-stage black powder night shoot where the coastal evening haze makes the gun smoke just hang there and creates those moments where visibility is just a notch better than invisible. This is also the place where a few under-breath curse words can be heard both before and after the bang.

Sunday morning topped off the weekend with an early morning Cowboy Church led by CVR's Bushy Blanco. At 10:00 a.m. our Men's and Ladies' Top 16 brought out the best to shoot for the gold. And at noon we were all back in the big tent for the Awards Ceremony.

"I think there's no secret," Sinful said, "that putting on a match like this takes a lot of dedicated folks who can attack a job and get it done right the first time. We had façades to paint, new signs to be made, a field to be plowed to make easier access for trailers, fences to be replaced with log rails, tents to put up, and much more. Somehow, it all came together... as it always does," he said. "As much as I would like to take a bow, the bow would not be for me but instead for our incredible team who just know how to get things done!"

"Striping the camping area [which can hold 168 trailers] was lucky this year," chuckled Trapper McDaniels (SASS #79238), our Campsite Manager. "Three years ago, we came out to stripe the trailer sites on the Saturday before the match and the next day it rained! So, we had to stripe again." Trapper added "And, the year after, the very same thing happened! And that's pretty strange because we just don't get rain in August. Sadly we had to cancel our match in 2020, but to be sure we weren't being jinxed, I still paid attention to the weather that Sunday and what do you know — it didn't rain! I was going to take bets from the striping team this year but I didn't want to risk it jinxing it," he laughed.

For those not camping or tenting on site, the CVR range is 15 minutes from the university town of San Luis Obispo to the south, and about the same distance to the coastal village of Morro Bay to the north; both of these towns are loaded with motels. And if you are okay with being 25 minutes away from the match, the motels in Atascadero (just over the hill from our range) are a bit less expensive.

"We got a bigger tent this year," said Jacq Neat (SASS #93557), CVR's Banquet Manager. "Not only did we anticipate a bigger crowd, but we were also concerned about distancing and making our attendees comfortable." She added, "with the ridiculous increases in food costs, I worked closely with our caterers to ensure nothing would be missing from CVR's much heralded Five-Star Saturday night banquet, and from what I heard from several folks, we knocked it out of the park... again."

Jacq Neat is right about the top-notch dinner, and the eating and greeting was crowned by the heralded Monte



WITH FOUR SHOTGUN TARGETS DOWN, JOHNNY LONGSHOT (SASS #81927) REACHES FOR HIS WINCHESTER TO BEGIN THE RIFLE STRING.

Mills and his Lucky Horseshoe Band who provided the best cowboy music one could eat to and dance to.

"I always like metrics and measuring what and how we are doing," said El

Lazo (SASS #13116), our other Match Co-Director. "To this end, Sinful and I continuously question whether we're on the right path and whether we are delivering the kind of Cowboy Action Shooting™ event our attendees want to attend," he said. "It's a hard thing to measure and the only thing we can go on is the comments and compliments Sinful and I get during the match. But what really drives it home are the emails and calls we get after the match thanking us and our team for putting on an excellent match. When folks go that extra distance, we know it means something to them, and that we're doing the right thing."

The SASS Western Regional is a not-to-miss event that caters to top guns and first-time match shooters with equal care and attention. And this year, our 27th Annual, is going to be even better.

The 2022 SASS Western Regional – 27th Annual Chorro Valley ShootOut will be held August 10-14, 2022. Registration and camping reservations can be processed on-line at www.chorrovalleyregulators.com using CVR's custom registration system. Our on-line camping reservation system lets you see which sites are taken and who is at that site.



BUCK GARRETT (SASS #47172) CLEARS HIS SHOTGUN ON THE FLY AS HE DASHES TO COMPLETE HIS RIFLE SEQUENCE.

Come on out and shoot the SASS Western Regional with us!

Roger Rapid is a frequent Cowboy Chronicle contributor and a member of the Chorro Valley Regulators.

TEXAS JACK

has *Any and All Things*
Wild West!

Bundling deals on
[www.texasjacks.com!](http://www.texasjacks.com)

- Buy 1 old west women's top and 1 old west women's bottom and get 15% off
 - Buy 1 old west men's shirt and old west men's pants, get 15% off
 - Buy 1 old west boots and old west shirt get 15% off
- 1 bundle per order please! Free shipping on orders over \$100 on clothes!



Family owned and operated since 1995.



Fredericksburg, TX.



1800-TEX-JACK

EDITORIALS



Skinny's Soapbox

CORRECTIONS

Shamrock Sadie (SASS #78511) has pointed out to me the report published last issue detailing Overall Ladies at END of TRAIL 2021 was in error. It listed Bonnie Macfarlane (SASS #92385) as top lady, with Clancy (SASS #46433) second and Hot Tamale (SASS #78531) third. The correct statistics should be Bonnie Mcfarlane first, Missouri Mae (SASS #80828) second, and Shamrock Sadie third. My apologies for the mix up. Hopefully this will set the record straight.

Additionally, Aspen Filly (SASS #59535) was correctly identified as first place winner, Ladies' B-Western, in the costume contest, but the photo run was not her. My apologies for that as well. I would like to run a correct photo, but hard as I look, I can't find one. If one of our readers has a photo from EOT 2021 of Aspen Filly in her winning outfit, please send me a copy and I'll run it in the next issue.

TRAILMARKERS

Last issue, I lamented the recent passing of so many Cowboy Action Shooting™ friends in recent months, and in response, Grey Fox (SASS #223) came up with what I think is a great idea. He sent me a "Happy Trail Marker" about his friend The Apache Kid (SASS #37), who just turned 82 and is still competing. You can read it elsewhere in this edition. I think this is such a good idea, I encourage everyone out there to participate and make Happy Trail Markers a regular feature. If you know a SASS competitor who is 80 or 90 (or dare I hope for 100?) and still active, please write up an article about them and send it to me. I look forward to seeing them.

COMIC BOOK CORNER

It seems readers either love or despise this segment. Many pass it by, but just as many tell me it's the first thing they read — enough that we'll be keeping it for the time being, in digital issues only.

This time around we're featuring "Buffalo Belle" from the first issue of *Blazing West* (Fall, 1948). It's interesting to note that, even though the cover is rather violent and gory, the interior stories, including Buffalo Belle, are fairly tame, run of the mill potboilers. Apparently the publisher's sales department reasoned a lurid cover would draw buyers. I guess marketing hasn't changed all that much over the years.

This story and many others (not just Westerns) can be viewed at comic-bookplus.com

—Skinny, SASS #7361



GOLDEN GATE WESTERN WEAR

Old west and contemporary hats, apparel, boots, and accessories for the whole family. Our Custom hats are hand-formed by Bill Knudsen, 9-time winner of True Wests magazines Reader's Choice award for Best Hatmaker.

Cullen Bohannon



Gus



See our online catalog at www.KnudsenHats.com

ORDERS: (510) 232 - 3644

UniqueTek.com
Products for Shooting, Reloading & Competitive Marksmen

Purple Metal Polish
High-Performance Brass Polish!

- 25% Faster
- Higher Shine
- Sealers Slow Tarnishing
- No Ammonia
- No Silicones



Quick-Release Case Cleaner Knob

- Quick On / Quick Off
- Brass Threads
- Sizes for Most Case Cleaners

It's not just unique, it's UniqueTek!™

Order Now!
Visit our Website at www.uniqueetek.com/chronicle
Or call 480-507-0866

NEWS

HONORING AMERICAN VETERANS AFIELD 2021

BY BEANS AHGIN, SASS #65626

Members of the South Texas Pistoleros and the Texican Rangers Cowboy Action Shooting™ clubs spent the weekend of October 22-24, 2021 as volunteers for the Honoring American Veterans Afield (HAVA) Field Day event in Bandera, Texas. The event provides opportunities for disabled veterans and a family member to explore various shooting sports with industry professional shooters, factory representatives, local IDPA folks, and Cowboys!

SAPD cancelled the HAVA 2021 event originally scheduled for October 9 at the Police Academy due to COVID. Upon learning the HAVA event had been cancelled, many competitors “pivoted” and registered for the Texas Black Powder Championship in Marble Falls,

or the Arizona State Championship in Tombstone, AZ before the alternate date was announced by HAVA. Still, many Cowboys and Cowgirls volunteered themselves and their guns for at least one day at the event.

The Caprock Kid was “ramrod” for the Cowboy Action Shooting™ stage. He had spent the previous week hauling shade tents, steel targets, tables, blankets, and target paint from the CAS range at A Place To Shoot to the Bandera Gun Club facility. Caprock (a different Cowboy) and Burly Bill Brocius spent a part of Thursday setting up the range.

SASS Members Latigo Lee, PJ Mugwump, Long John Beard, Natalia Sue, The Caprock Kid, Burly Bill Brocius, Maid Jalaff, Sauk Valley Sam, Newt Ritter, Canyon St. Clair, Whiskey Moss, Big John Mesquite, Davey Lunchbox, Thunder Mountain, and Beans Ahgin volunteered for at least one day at HAVA. Colonel Colt Winchester was among the first to raise his hand, but health issues kept him from participating.

Throughout each day of the event, “squads” of veterans and family members cycled through five different activities. CAS folk served as Coaches, Range



Safety Officers, Loaders, Unloaders, Brass “Picker-Uppers,” and Facilitators for the CAS activity.

A catered BBQ lunch provided by HAVA each day kept everyone fueled-up. There was live music in the Main Tent. Pallet loads of bottled water were consumed. Over three days, the participants on the CAS stage alone fired more than 2,400 rounds of “Cowboy Ammo.”

At the end of the Awards Ceremony each day, an informal Exit Poll was taken by applause. The Cowboy Action Shooting™ stage was far and away the favorite. HAVA has asked that we come to the 2022 event to be held at the Bandera Gun Club.

HENRY REPEATING ARMS DONATION RAISES MORE THAN \$40,000 FOR INDIANA GIRL'S CANCER TREATMENTS

RICE LAKE, WI, Mar. 15, 2022

— Henry Repeating Arms, the country's leading lever action firearm manufacturer, is pleased to announce its donation of 55 custom rifles raised a total of \$40,660 for four-year-old Milah Schevenius of Decatur, Indiana. The funds will provide financial assistance for the medical expenses incurred throughout Milah's kidney cancer treatments, including several surgeries and 42 weeks of chemo and radiation. Milah was diagnosed with bilateral Wilms' Tumor, a rare occurrence affecting only six percent of Wilms' tumor patients.

The "Miss Milah's Miracle" campaign is the latest fundraising effort of Henry's Guns For Great Causes program, a charitable branch of the company that focuses on providing support for sick children, children's hospitals, military veterans organizations, and other non-profit groups. Each rifle in the

limited-edition series features a colorful, childlike design unique to Milah's personality engraved and hand-painted on the walnut buttstocks. All the rifles sold out within three hours of the initial release announcement. In addition, the online auctions for the first and last serial numbers in the limited series ended at \$5,850 and \$4,600, respectively.

"I am in shock; this is just still so surreal," said Keyara Schevenius, Milah's mother, after learning how fast the rifles sold out. "I would never have imagined how big this would get when we first heard about what Henry was doing for Milah... our little girl is so loved!"

Anthony Imperato, Founder and CEO of Henry Repeating Arms, said, "We are so grateful to everyone that chooses to support Guns For Great Causes, from those who purchase a rifle to partners like Baron Engraving that donate their time and services." Imperato continued, "To Milah and her family, I wish you continued strength and blessings on the road to remission. Sending you a big hug!"

All Henry firearm purchases must transfer through a federally licensed firearms dealer. For more information about Henry Repeating Arms and its products, visit henryusa.com or call 866-200-2354.



SHOOT FOR A CURE 2021

BY ONE EYED JANE, SASS #85629 AND CODY MAVERICK, SASS #93440

Since 2012 (except the Covid 19 year of 2020) on the third Sunday of October in Shackelfords, VA (home of the Mattaponi Sundowners and the West Point Gun Club), partners have joined together to raise money for "The Turtles" our local Relay for Life/American Cancer Society.

Pat Graves (Sassy Shooting Sours, SASS #67591), the founding mother of this event had asked we donate \$1 more than the year before. In addition to the match fees donated and a \$5 per person donation from West Point Gun Club for everyone who pre-registers and then shows up to shoot, there are lots of folks behind the scenes making items and getting donations. A big thank you goes out to Wistful McClintock (SASS #91763) and Inita Shoot (SASS #93743) for purchasing and selling \$6,000 worth of "Shoot for A Cure" tee shirts.

One of our big supporters is Green Top, a local beloved hunting, fishing, and general merchandise store. They donated a \$400 gift certificate this year. The Mattaponi Sundowners are invited to have a table at their "Expo" where we sell raffle tickets for the certificate. This is a large task and folks from other clubs take a shift.



MILAH SCHEVENIUS



At the match there are tables of donated scarfs, pictures, wild rags, gun socks, jewelry, homemade wreaths, and delicious treats to name just a few. Another table will have items to be included in raffles, purses, carved ornaments, and gift certificates from businesses near and far. One of the most sought-after items is the stool with the leather carved and tooled seat made by Corkscrew Tom (SASS #68972).

A cool windy day October 17, 2021 saw 35 shooters arrive all decked out

in pink or purple for the match and its traditions. After the pledge of allegiance seven survivors from any type of cancer line up with their shotguns to honor and remember those who lost their battles with a 21-gun salute. Each year an honorary sheriff is selected and presented with a loading block made by Potter County Kid (SASS #67357). The number of years as a survivor is represented by beads in the appropriate color for the type of cancer. Also, each past honorary sheriff is given a single bead to add to their loading block. Honorary sheriff for 2021 is Flatboat Bob (SASS #32310).

All targets are painted pink and purple. One bay even has targets arranged to look like the cancer ribbon. Starting line for the six stages is "SHOOT FOR A CURE!" or "I'M A SURVIVOR!"

After all props were torn down and safely stored away it was time to find out the lucky winners of the raffles and all the winners of the match. This year congratulations go out to Cody Maverick and Sassy Shooting Sours as the top male and female shooters.

GRAND TOTAL 2021 (drum roll please) \$19,029. Yeeha!

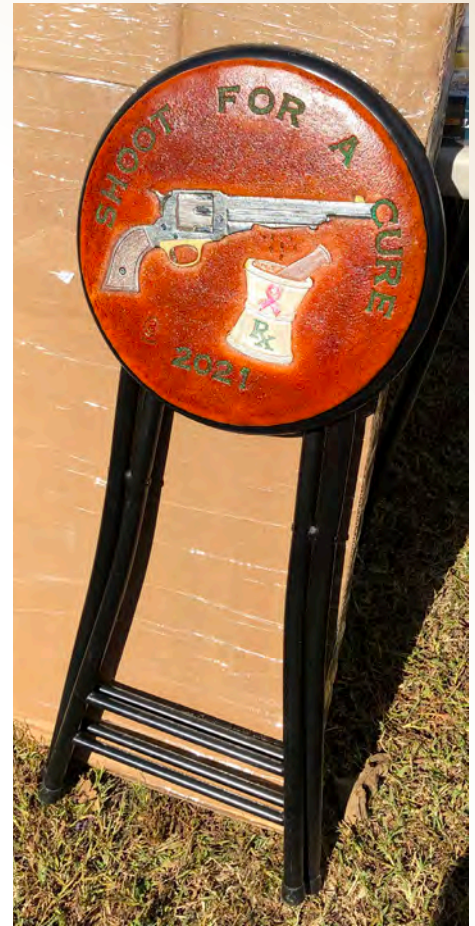

HENRY SIDE GATE LEVER ACTION RIFLE

.35 Rem | .38-55 Win | .30-30 Win | .45-70 Gov't | .410 Bore



Celebrating 25 Years



HENRY

Made In America, Or Not Made At All

FREE CATALOG
Scan or Visit
www.HenryUSA.com



SCAN HERE

ANNUAL MATCHES



The Ladies of the 2021 SASS Canadian National Championships

SASS CANADIAN NATIONAL CHAMPIONSHIP 2021 HALLELUJAH, WE'RE BACK!

BY KOOTENAY JACK, SASS #79341

Mission & District Rod & Gun Club, Mission, B.C. Canada, September 3-5, 2021. Well now, that was fun. Even if I didn't get to shoot, I thoroughly enjoyed watching those who did. It's been quite a ride since March of this year when we were asked to take on the Nationals. Last year's event had to be cancelled due to Covid, so it was really important we get one on for this year. We knew this year was going to be filled with its own challenges but we could see a little light at the end of the tunnel and it helped us keep the hope alive. There was talk about lifting some of our restrictions in phases come summer time and that would allow us to have the event. Although we knew it would be a lot different from any of

the past Nationals we have had. First, we would be limited to the number of shooters we would be allowed to have at the event. Second, we had no idea if our Clubhouse would be open for gatherings or meals. Still, there was that glimmer of hope, so we forged ahead. Summer arrived and with it the easing of some restrictions and we actually believed it was all going to work out just fine. By August we were allowed to increase our numbers and

it was finally confirmed that our Club and Cafeteria would be open and providing meals for us but we would be limited to a maximum of 65 people in the Clubhouse at any one time. This would present a bit of a problem but could be worked out. We reopened registration and moved people from a waiting list to a confirmed shooters list. More began to sign up, things were looking good. Then the fourth wave of Covid started to take hold and more wild fires began burning up our forests. Those started getting out of hand with some areas being evacuated, some waiting on evac notice, and the smoke getting so bad it was affecting peoples' breathing. The smoke was so bad at times you could see it from the Pacific Coast to the Rocky Mountains. With the fires and Covid we started to lose some of our registered shooters and by the time we were actually ready to start shooting we were down to just 52 participants, a far cry from the usual numbers — well over 130 — we would normally have. Plus, our Province put the mandatory mask restriction back in place for inside buildings. However, that was the worst of it and Friday



Top Canadian Lady Georgina Bank, Top Canadian Male Whistler Will, and Top International Shooter Joe Cannock



Posse #1



Posse #2



Posse #3



Posse #4



morning, September third we started our side matches and didn't look back from there. The Side Matches went off without a hitch and the Main Match on Saturday and Sunday went well too. Even the weather cooperated. It was great seeing friends we hadn't seen for almost two years and enjoying the sport of Cowboy Action Shooting™ which we have truly missed.

The Canadian Ladies Champion is Georgia Bank (SASS #86344) and the Canadian Men's Champion is Whistlin' Will (SASS #86382). We were also fortunate to have Joe Cannuck (SASS #58702) from Bellingham, Washington, join us and he is Top International Shooter.



Clean Match Award - Whistlin' Will,
Mustang Heart, & B. Slim

CIMARRON F. A. CO



1875 OUTLAW - 5 1/2", 7 1/2" (SHOWN)
.357 MAGNUM/.38 SPECIAL, .44 WCF, OR .45 COLT

Not Just Another Importer

CIMARRON FIREARMS IS THE *PERIOD CORRECT* CHOICE. SINCE WE BEGAN IN 1984, WE HAVE WORKED TIRELESSLY TO BRING AUTHENTIC OLD WEST FIREARMS TO SHOOTERS, COLLECTORS, AND COMPETITORS WHO KNOW THE DIFFERENCE. CIMARRON WORKS WITH IT'S MANUFACTURERS TO RE-INTRODUCE HISTORIC MODELS AND CALIBERS. BECAUSE OF THIS, CIMARRON LEADS AND OTHERS FOLLOW. DON'T JUST GO HALF-WAY WITH THE OTHER GUYS. IF YOU WANT QUALITY AND AUTHENTICITY, YOU NEED A CIMARRON.

WWW.CIMARRON-FIREARMS.COM

1877-SIXGUN1



DEFEND THE FORT TOP SHOOTERS STILL SMOKIN AND WILD WENDY

DEFEND THE FORT 2021 "GONE BUT NOT FORGOTTEN"

BY SLOWAZ MOLASSES SASS
#41444

Fort Parker, November 19-21 — Groesbeck, Texas. This year's charity match is dedicated to those shooters that supported the Fort over the years and have passed on. All of

them were patriots with a love for Cowboy Action Shooting and the Old West. They are missed.

Our only commercial sponsor this year was Wild West Mercantile and we thank them for continuing to support this worthy cause year after year. You may not know this, but the Fort doesn't receive any funding from the state to keep this historic restoration open. I would like to thank all the Cowboys and Cowgirls that made and donated items to be raffled off.

The money raised from this event helps with the day-to-day operations and keeps these doors open.

Side matches started Thursday morning with long range shooting from the blockhouse until noon, then speed events, a two-stage warm up, and three-stage Wild Bunch match. The husband and wife team of Brushy Creek Bill (SASS #49466) and Mar-Lynn (SASS #94314) both won their Wild Bunch categories while shooting clean. Former Vice President Colorado



Jackson used to tell everyone shooting clean was overrated, but I'm sure these two would tell you different. The 10-stage main match started Saturday morning with speed events after for those who could not attend on Friday. The main match concluded late Sunday morning. When the dust settled, 97 shooters from four different states completed the match. Our Top Cowgirl was Wild Wendy (SASS #98295) and Top Cowboy was Still Smokin (SASS #62301).

I would like to thank everyone who worked on the range or helped out in any form or fashion. We couldn't have done it without you! A special thanks to Texas Gunslinger (SASS #10706) for once again being the match director, Reckon (SASS #35883) for being the range officer, and Calico Callie (SASS #60761) and Denton Dancer (SASS #60759) for handling all the scoring.

I hope you will put this match on your calendar and plan to attend.





VETERANS WHO ATTENDED MASON DIXON STAMPEDE.

MASON DIXON STAMPEDE 2021 HONORING OUR HEROES

BY MISFIRE MAGGIE, SASS
#69350

For 2021's theme the Mason Dixon Stampede Committee chose to honor the brave men and women of our armed forces. A special Challenge Coin was designed and given to each shooter. Special pins were presented to identify the veterans attending the match and non-veterans were provided

with a "Support our Veterans" pin.

Friday, July 30th, was Side Match Day and Red Shirt day to "Remember Everyone Deployed." Side matches included a three-stage mini warm-up match, long range, and the usual speed events.

Saturday morning opening ceremonies began with the Presentation of the Colors, the Pledge of Allegiance, another beautiful rendition of the National Anthem by Calamity Jill (SASS #86159) and a prayer led by Lash Toru (SASS #85004). After a quick and efficient safety meeting by Range Master Montana Max (SASS

#81717) shooters headed to the shooting bays.

Based on shooter feedback from the 2019 match, the main match was changed to five stages on Saturday and five on Sunday. Stages one through five highlighted a service and the starting line was the service motto. Stages six through ten highlighted five real heroes who played Western heroes on the Silver screen — Audie Murphy, James Stewart, James Arness, Lee Marvin, and Henry Fonda.

As long as Dutch Coroner (SASS #82128) is the Match Director, our match will feature big, close steel with



MASON DIXON STAMPEDE COMMEMORATIVE CHALLENGE COIN



TOP WOMAN SUNSHINE MARCIE WITH TOP MAN AND TOP OVERALL TOMBSTONE COTY.





MASON DIXON STAMPEDE SHOOTER'S PINS

lots of movement. As Dutch likes to say, "It's a pain to put up, but it's fun to shoot!" The match featured down-range movement on four of the ten stages. The water trough was a new prop everyone enjoyed and the swinging target was back. There were rifle and revolver knockdowns (that could be made up) and on stage eight you pushed down a door to begin the stage.

After all guns had been put away on Saturday, everyone was invited to the ever-popular Wooden Nickel Saloon for "Beverages & BS." Following was a catered dinner by Mission BBQ during which side match awards were handed out. The dinner was a big hit with the shooters.

On Sunday at 9:00 a.m. the final five match stages began and shooters were finished around 1:30 p.m., enough time for everyone to put away their guns, check out the vendors, and pay one last visit to the food vendors before heading over to the big tent for the main match awards presentations.

In 2019, Two Gun Tuco (SASS #78297) edged out Tombstone Coty (SASS #101540) by .02 of a second. In 2021, Tombstone reversed that result, convincingly, to be the Top Man and Overall Shooter, winning six of the ten stages. Top Lady was Sunshine Marcie (SASS #64900), finishing 19th overall.

One huge addition to this year's match was the raffle for a genuine 2nd

Gen Colt Single Action Army generously donated by Geronimo Jim (SASS #21775). Every registered shooter was automatically entered into the raffle. The winning ticket was pulled right before the announcement of the Top Man and Top Lady. The winner... River Banks (SASS #55949).

There were 113 shooters. We hope to welcome even more in 2022. The Mason Dixon Stampede "Lawmen of the Wild West" Match will be held August 5 through 7. We hope to see you there!

All scores can be found on our website, <https://masondixonstampede.org/home/>

Trusted
When your reputation is on the line, trust in the industry leader in performance and accuracy.

Oregon Trail® guarantees your satisfaction unconditionally.
As shooters, we have absolute confidence in Oregon Trail® bullets, the confidence you need when your shot has to count.

- No leading
- Silver alloy yields extreme accuracy

1-406-883-0741

Oregon Trail® is a registered trademark of Oregon Trail Bullets Company. © 2020 by Oregon Trail Bullets Company. All rights reserved. oregontrailbullets.com



THE TEJAS CABALLEROS MANDATORY SAFETY MEETING BEFORE THE START OF SHOOTING COMPETITION AT DETERMINATION, TEXAS.

THE WHOOPIN' RETURNS! FIVE YEAR DROUGHT IS ENDED

BY JUDGE MENDAY COMING,
SASS #65165

The Tejas Caballeros Cowboy Action Shooting™ Club of Blanco County, Texas ended a five-year absence of its annual invitational shooting competition October 15-17, 2021. Sixty-two shooters from across Texas competed for top honors in the three day event.

The Tejas Caballeros, a 21-year established Texas club, moved to Blanco County in 2016 after losing its Travis County range to the advancement of subdivisions into formerly rural land. With a new location and a 99-year lease on private ranch land 7.6 miles northwest of Blanco, the club began construc-

tion of the “new” old west town and shooting range of Determination, Texas. The club’s first shoot in Determination was in January 2017.

After four years of construction Determination now boasts a city hall, city hall annex, bank, saloon, emporium for gentlemen, post office, western union, barber shop, cattle company, livery, wheelwright service company, silver mine office, outlaw cabin, covered wagon, sheriff’s office and jail, gallows, and a cemetery. A total of 10 individual shooting stages designed to encourage the world’s fastest growing family shooting sport of Cowboy Action Shooting™ (CAS).

CAS shooters converged on Determination for Long Range shooting competition on a perfect Friday morning. Using rifles either produced or patented in the late 1800s, contestants spent the morning engaging steel targets from 100 to 400 yards in a timed

competition of long range accuracy. The afternoon was dedicated to CAS side matches.

On Saturday morning 62 CAS shooters from age 12 to over age 80 began the competition of single action revolvers, lever rifles and cowboy shotguns. Some were blazing fast with timed scores of less than 20 seconds to place 24 rounds on target from four different weapons. Others were not as fast but just as accurate in the multiple age competition categories.

THE COWBOY JAMBOREE

Saturday night was party time as the shooters, spouses, and significant others gathered in the famous Blanco County Courthouse for an old time Cowboy Jamboree. The Blanco Courthouse was the film site of the courtroom scene in the movie *True Grit*. The Jamboree was hosted by the Texas



MEMBERS OF THE TEJAS CABALLEROS ENJOYING FARO, THE MOST POPULAR CARD GAME OF THE AMERICAN OLD WEST IN THE MIDDLE TO LATE 1800S.

Republic Ranches Legacy Foundation (501) (c) (3). Guests participated in a costume promenade contest, Old West Faro table for fun, a “Stretch Raffle” with prizes from art to clothing to guns donated by area merchants, and a Dillon 750 loading press donated by the foundation. Dinner was provided along with assorted beverages and a free bar with beer, wine, and setups. The evening’s final event was a live auction for a pair of hand-engraved sequentially-numbered stainless steel Ruger Vaquero revolvers, fully tuned for Cowboy Action Shooting™.

Shooting competition resumed at Determination on Sunday morning for the final four stages. After the morning shooting, a lunch of venison chili was provided by the Tejas Caballeros and Dragon Hill Dave (SASS #59561) of Austin.

In the final accounting of timed and accurate CAS competition the overall Men’s Champion was Alamo Andy (SASS #101775) from San Antonio. The Women’s Champion was Brazos Belle (SASS #82399) from Lipan, TX near Fort Worth.



WHOOPIN’ OVERALL WINNERS BRAZOS BELLE AND ALAMO ANDY

SASS & DIXIE DESPERADOS 2022



LEGENDS



April 18-23 St. George, UT



Applications: www.dixiedesperados.com

10 Wild Bunch Stages / 12 Main Match Stages
Side Matches & Speed Events * Costume Contest * Raffles
Camping * Vendors * Awards.....and more!!
Shoot one or shoot 'em both.....but
let's play in beautiful S. Utah



Main Match Director: Bit Younger - clark_poulton@q.com
Wild Bunch Director: Mokaac Kid - mokaackid@gmail.com
Registration: Lucky Wheeler - lwheeler38utah@gmail.com

DISPATCHES FROM CAMP BAYLOR COLT FARO LEATHER

BY CAPTAIN GEORGE BAYLOR,
SASS #24287 LIFE REGULATOR

For beginners, I must first mention we are not re-enactors. If you want authentic old west rigs, there are some excellent makers, but you will realize you have made a mistake using them for SASS® competition when you try to reholster on the fly using one hand while the other grabs your second revolver. You will also realize you can't grab the weak hand revolver in a way to facilitate switching to your strong hand. The rig won't be stiff enough to hold its shape. The holster will close when you pull the gun out, and you won't be able to get it back in with one hand.

COMPETITION HOLSTERS

There are very few holster makers who understand this sport. Others might be great leatherworking companies making historically authentic rigs.

Colt Faro makes rigs for SASS COMPETITION, not reenacting. He uses a Cobra Class 4 sewing machine and a Cobra burnisher. He uses a hydraulic press to click out standard parts that he uses all the time. He's getting a laser engraver and cutter to further expand his capabilities. I mention this because if you expect to take custom orders you must be able to work at professional speed. If you don't have them, you're a hobbyist. He's part craftsman, part very particular competitor who accepts only perfection, and part artist.

He makes competition holsters that look like they should be framed on the wall of some sort of art gallery, but they WORK. This rig is VERY functional. It also looks great. Think of it as the equivalent of a custom engraved, ivory handled pistol. They still shoot, but are eye catching, too.

WHO IS COLT FARO?

I met Colt Faro early in my SASS



COLT FARO LEATHER AMERICAN HERO RIG. THE BODY IS MADE OF ELEPHANT AND HAS A GATOR OVERLAY. ANTIQUE BRASS PARACHUTE SPOTS WITH DECORATIVE ACCENTS.



IT HAS A VERY HIGH-END TRI-COLOR FINISH, ANTIQUE BROWN WITH BLACK ON THE INSIDE AND THE COPPER-WASHED GATOR.



THE AMMO POUCH CLIPS OVER THE BELT. POUCHES MADE AFTER THIS WILL HOLD THE ST MACHINE LOADING BLOCK, WHICH CATCHES UNCRIMPED RIMS, SPLIT RIMS, AND HIGH PRIMERS.

career in Texas. We shot a lot together. We've been friends for about 20 years. He has become a champion shooter. For those of you who don't know him, you've probably heard of his son, or seen him on the cover of *The Cowboy Chronicle*. Matt Black, who has won that title of SASS Overall World Champion five times. When I met him, he was coming to matches when he was too young to shoot SASS, somewhere around 8-10, at local matches he shot .22s with his father hovering over him. A few years later he was winning matches overall while still a buckaroo.

During that time Colt was making holster rigs, sometimes showing up with a new one every month, and people started buying them, sometimes right off his body. He had help. "Matt is the pickiest person I know when it comes to his equipment, so I had the worst critic ever living with me and eating my food, lol. He would say to me, dad my gun rig has to be perfect because I am going to be an Overall World Champion someday. Well that he absolutely did."

HIS RIGS GOT BETTER AND BETTER

"After lots of prototypes over the years I have landed on perfection as we see it for the sport of Cowboy Action Shooting™. We start out with a platform and there is only one these days that I build for my customers. The Colt Faro Elite platform is everything you could want in a Cowboy Action holster with-



TOP GUN SHOTGUN BELT. 100 PERCENT ADJUSTABLE STRAPS (BILLETS), ELEPHANT BODY, DOUBLED OVER FOR CLEARANCE, SUEDE ON BACK, WRAPPED BOTTOM. ELEPHANT LOOPS ARE SNUG FOR 12 GAUGE SO YOU JUST PULL THEM UP UNTIL YOU HAVE THE RETENTION YOU WANT. ROUNDS DO NOT BIND.



ANTIQUE FINISHED BUCKLES GO WITH THIS RIG. WITH THIS KIND OF BUCKLE YOU CAN YANK THE BELT TIGHT, ESPECIALLY IF YOU WEAR IT LOW.



OVERSIZED BUCKET, DESIGNED FOR COMPETITION. MAKES A BIG TARGET TO HIT WHEN RE-HOLSTERING. TOP ANGLES AWAY FROM YOUR BODY AND MUZZLES ANGLE IN. ADDITIONALLY, YOU CAN GRIP THE WEAK HAND REVOLVER WITH FOREFINGER UNDER THE TRIGGER GUARD. YOUR THUMB GRIPS THE TOP STRAP. THEN YOU CAN GRIP YOUR STRONG HAND IN A FIRM FIRING GRIP. NO FUMBLING!

out it actually shooting the stage for you.

“The way it’s cut helps to make the bucket on the holster quite large and visible. The steel lining that goes between the layers of leather keep it from having any movement while you are moving. The steel also allows you to adjust the holster so it is as close or as far away from your body as you like. After you get it bent the way you want, it stays there unless you decide to change it. The ¾-skirt angles the holster cleverly inward at the toe just making it that much more ergonomic. Each CFL Elite rig comes with the incredible Holster Clamp System. This system allows you to lock the holster down on the belt, so they don’t slide. You always want your holster in the same place every time and the Holster Clamp System makes that happen. You slide your belt through the channel behind the clamp and when you get it where you want it on the belt you simply tighten the screws on the back of the holster. This has been a total game changer for many shooters out there!”

ORIGIN OF THE “AMERICAN HERO” RIG

To do this article I needed product to test and review. You can’t write intelligently about holsters unless you use them. Looks are maybe 30 percent, and function is 100 percent. Yes, I know that doesn’t add up. I knew Colt wanted to show off his artistry, so I left it up to him.

Every rig I’ve seen has been different, with various exotic leathers and other materials, such as acid washed copper. They’ve all been heavily decorated.

I had no idea what he was going to come up with. He asked me what the shoulder patch my unit in Vietnam wore. That gave me a clue.

When I saw the pictures, I was stunned at the artistry and humbled when he called it the American Hero Rig. I served with heroes, but I’m not one. I’m a combat vet.

You’re looking at pictures. Everyone who has seen the rig has said the same thing. “The pictures don’t do it justice.”

I have taken probably a hundred photos with two different cameras, several backgrounds, and different lighting systems, and I still agree with that statement. The multi-toned leather looks different in different light.

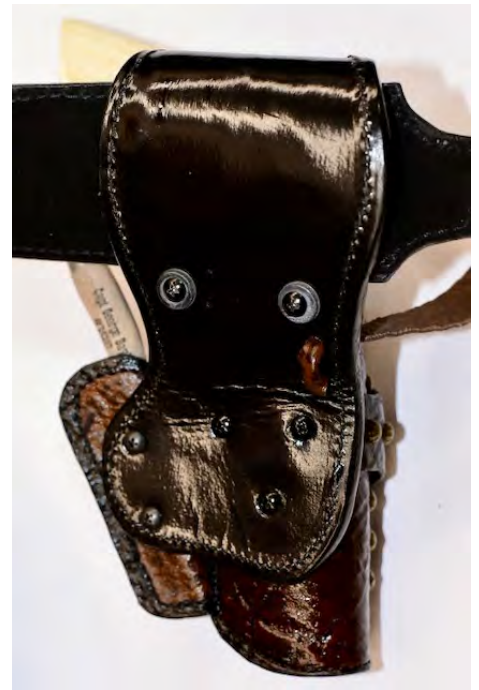

THE HOLSTER IS LOCKED IN PLACE BY THE CLAMP SYSTEM. THE CLAMP INSIDE IS ADJUSTED WITH THE TOP TWO #1 PHILLIPS HEAD CHICAGO SCREWS. LOOSEN THEM, SLIDE HOLSTER INTO POSITION, TIGHTEN. THE HOLSTER WON’T SLIDE AROUND.



THE POUCH IS HELD IN PLACE BY A SPRING-LOADED HOLSTER CLAMP.



YELLOWSTONE HOLSTER AND BUCKLE. COLT BOUGHT ALL THE BUCKLES A STORE HAD, ANTICIPATING A DEMAND.



A "BASIC" RIG IN ANTIQUE BROWN. THE EXTRABLING IS FUN, BUT THIS ONE WILL BE AS FUNCTIONAL.



A HOLSTER FOR WYATT EARP'S BUNTLINE.



HAMMERED COPPER METAL INLAY SURROUNDED BY A COMBINATION OF ANTIQUE BRASS AND ANTIQUE COPPER SPOTS.

HOLSTER FEATURES

Functionally, the holsters are well-designed for competition. The top angles away from your body and the muzzles angle in. Additionally, a feature I consider mandatory is you can grip the weak hand revolver with forefinger under the trigger guard. Your thumb grips the top strap. Then you can transfer to your strong hand in a firm firing grip without fumbling. Your weak hand isn't in the way of your strong hand. Do not buy holsters for serious competition without this feature unless you shoot double duelist/gunfighter or use a cross-draw holster. Even then it's a good feature.

It has an oversized holster band with the MACV Crest (Military Assistance Command, Vietnam) and crossed rifles. Obviously, those were specific mementos. Of course, he could do others.

The body is made of elephant and has a gator overlay. Antique brass parachute spots with decorative accents. It has a very high-end tri-color finish, antique brown with black on the inside and the copper washed gator.

Each holster has a Screw Knife scabbard. You can keep two Screw Knives or the included Lutz Two-In-One screwdriver that comes with a #1 Phillips screwdriver (for the Chicago screws in the rig) and a slot head that fits the grip screw and ejector rod housing screw of a Ruger Vaquero (the only



THE EMERALD CANYON RIG.



THE SILVER KING RIG WITH A THIRD CROSS-DRAW HOLSTER.



SHOOTING BULL'S SPECTACULAR RIG.

gun I've tested it on), so you can check them at the loading table. If you've ever watched a Ruger ejector rod housing go down-range, you'll know why this is a good idea. You also get what I call a Colt Faro Leather Army Knife that has, among other blades, a #1 Phillips, scissors, and most important, a corkscrew. You want to have wine with dinner, don't you?

BELT

An antique-finished buckle goes with this rig. With this kind of buckle you can yank the belt tight, especially if you wear it low. This is more user-friendly than an award buckle.

There are belt options. Matt Black and the other guys who want their holsters in front and two hand widths apart use a belt that is buckled in the back. It is a curved belt for comfort and has removable billets so the size can be adjusted easily.

This rig has the Scout style, a standard one piece tapered on each end. It is suede lined. It works well for putting the holsters just in front of the point of the hip, angled forward like these, or further back and muzzle straight down. Getting them in front where you can see them is getting more and more popular in SASS.

TOP GUN SHOTGUN BELT

One hundred percent adjustable straps (billets), elephant body, suede on back. Wrapped with elephant and doubled over for clearance. Loops are elephant with a limit strip on the bottom to keep them from going in too far. They are a snug fit for the 12 gauge shells so you push them all the way in and pull up to adjust retention. If it's a stand and deliver you might want to pull them up some. If the shotgun is last with lots of movement push them all the way in. I found the shells all the way in to be quite easy to remove. There hasn't been any binding. Sadly, I can't pick up six shells at once. (Of course, I couldn't pick up six shells with any other belt either.)

Three .38 reloads are on each side. Again, there is a retention strip below, and you can push them all the way in or keep them higher for the planned reload. The rounds came out easily when pushed all the way in.

CROSS DRAW RIGS

A lot of the fastest shooters use cross-draw holsters. Matt Black is one of them. Beginners start with cross draw holsters and get into trouble. The cross draw that Gus used in "Lonesome Dove" isn't legal. What works in SASS is the cross-draw in front of your weak side, pointed almost straight down. The requirement is the holster be within 30 degrees of vertical "AS WORN." Let your belt slip down in front and up in back, and you could be in violation. Needless to say, the Matt Black cross-draw rig with buckle in the back fits all of those requirements. All the rigs come with the Lutz Two-In-One screwdriver, the Colt Faro Army knife, an LED flashlight, and a backpack and bag for the rig.

BASIC RIG

Colt's rigs are not cheap, as you would expect from the quality. The basic rig is \$750 and the shotgun belt is \$275. You get what you pay for. He tries to keep up with orders, so you don't have long waits. That might change after this article is out and several thousand SASS shooters see them, though.

Email: coltfaroleather@gmail.com

Facebook: [Colt Faro Leather and Design](#)

EAGLE KIRINITE IVORY GUNFIGHTER GRIPS

I have written about Eagle Gunfighter grips before. They were designed by Joe Bowman and Raj Singh of Eagle Grips more than 25 years ago. They are thin with a thick portion at the top to prevent roll up in recoil. They are the dominant grips on Rugers in SASS. Until Kirinite came out most shooters would recommend checkered grips. Even Phil Spangenberg in *True West Magazine* recommended checkering.

But in testing some smooth Kirinite grips on 1911s, I realized they were so "grippy" I didn't need checkering and started using the smooth ones on my competition 1911s.

Then I realized they came in "Ivory." (Note: No cuddly little elephants were involved in this product, not even ones from 200 years ago). SAAs of all types, even Ruger Vaqueros look best with ivory grips. So that's what's on my competition Vaqueros. When you get a pair or two, before you fire off an angry letter that they're slippery, wash off whatever they're waxed with using a mild all-purpose cleaner. Now they're not, they're grippy. Yes, I use one of the liquid chalks on my hands. I did with checkered grips, too. I have ivory grips on my Colt SAAs, but I consider them too delicate to use in matches. These are tough. I thought they were perfect to cap off this rig.

General Patton would approve.



EAGLE GRIPS KIRINITE IVORY GUNFIGHTER GRIPS.

BLACK POWDER 101 HOW TO TAKE UP SMOKING WITH NO ADVERSE HEALTH EFFECTS

BY BLACKPOWDER BURN, SASS #39761

Bkay, so you've seen some folks at your local club or elsewhere shooting that nasty old smoky stuff and cackling and giggling like mad people. This is accompanied by big rolling BOOOMS! You wonder what the heck is so great? It's dirty, smelly, really hard to clean up, has to be cleaned every day (what a pain in the posterior!) and corrodes your expensive guns, right? So why would anyone do that unless they're a freaking idiot?

Well... while all the opinions expressed above are the prevailing "wisdom" about black powder, they are DEAD WRONG! Now I'm not saying you don't have to do some things differently, but it doesn't take much more effort and sure adds a whole new level of fun to our game. You actually get to shoot your guns with the proper all-organic "green" propellant they really used back in the day. After all, BP is made from charcoal, sulfur and bat excrement (the common source of the potassium nitrate needed).

For those of you who may have a slight itch to try black powder but maybe haven't been quite brave enough to actually confess it to anyone, I thought I'd write a few short articles about what is required to join the "Dark Side." They will include:

A discussion of common misconceptions versus what the truth really is; bullet design and proper lubrication; cleaning requirements (and how simple it is); reloading pistol caliber metallic cartridges; reloading shotgun; reloading long range rifle caliber for when you want to really reach out and "touch someone" at 500 to 1,000 yards — or more!

These won't contain all the information you might need, as there are a lot of variables (just look at all the different load recipes in any reloading manual), but will touch on the major issues and differences between black powder and that new fad, smokeless stuff. It will give you a good idea of

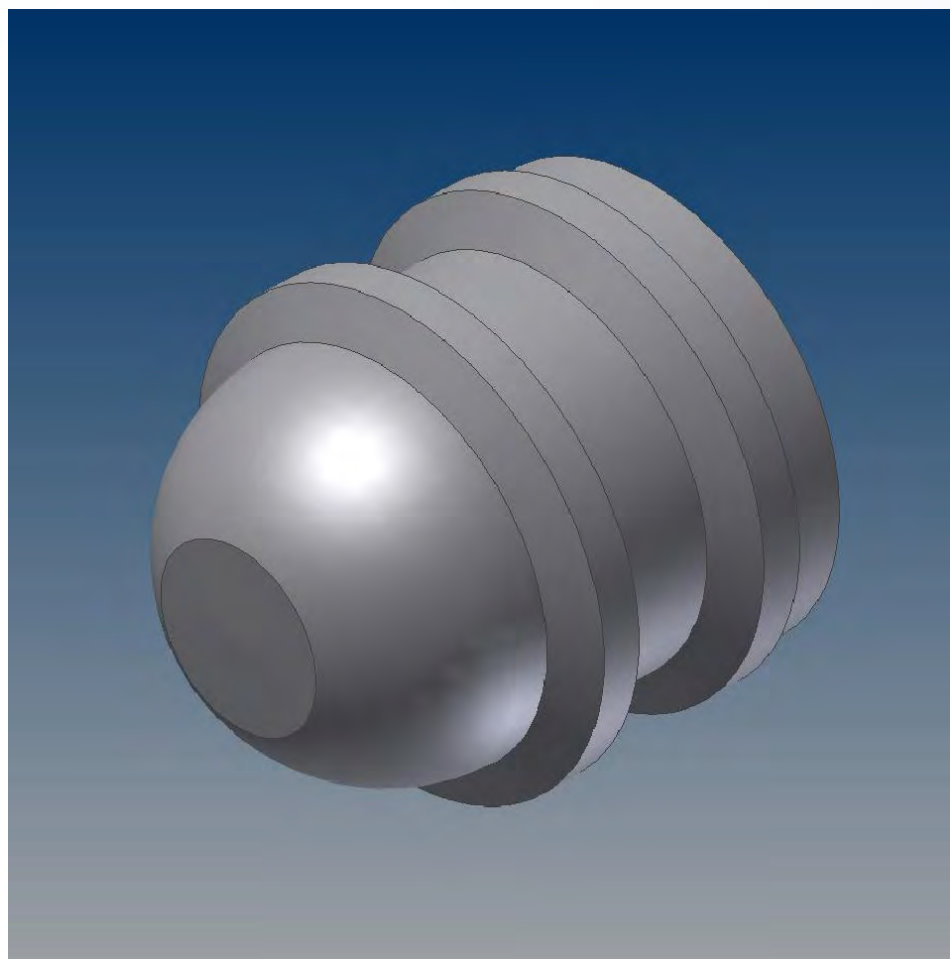
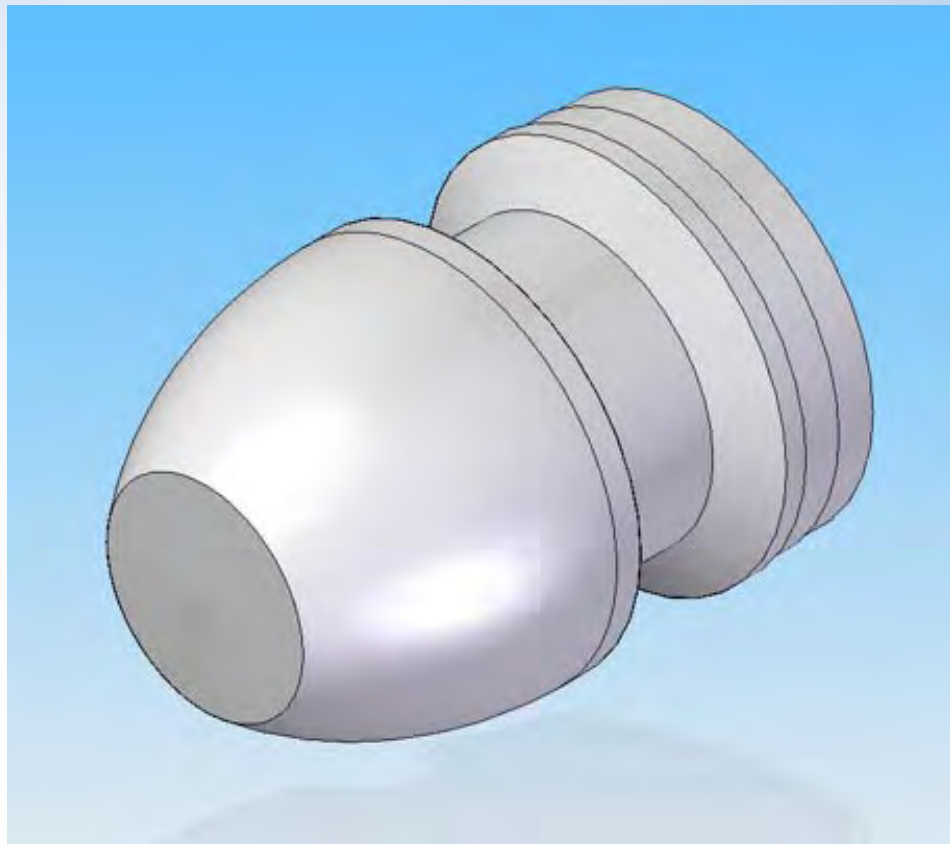

BULLET 1 AND BULLET 2
WHEN LOADING FOR BLACK POWDER CHOOSE A BULLET WITH LARGE LUBE GROOVES.

the things you need to do differently, and where BP is actually easier to deal with in a couple of ways. So... if you're gonna play Cowboy, do it right!

COMMON MISCONCEPTIONS

Let's face it, black powder has not been in common use by reloaders for more than 100 years. That being the case, a lot of knowledge about how to load with it has been forgotten. Well, not forgotten, it's out there if you dig for it, but it's certainly not common knowledge. And what "knowledge" folks have is mostly wrong. Think about the old game of whispering a sentence into someone's ear and repeating it around a circle. By the time it gets back to the originator, it bears absolutely no resemblance to the original phrase. That's pretty much the same thing with what most of us "know" about black powder — we've been "whispering in someone's ear" for 100 years and "knowledge" has been distorted into having little relationship to reality.

To begin, I'll tell the story of my first experience loading black powder. I had a new Cimarron 1873 Deluxe rifle in .44-40, all decked out and beautiful. After

all, if I'm going to play Cowboy, I'm gonna do it right with the original cartridges available "in the day." I loaded up some smokeless loads with seven grains of Unique (I'm no damn gamer!) and the rifle shot really well — life is good. So... I decided to play with some black powder loads. I'd been thinking about it awhile and decided the .44-40 rifle was the perfect gun with which to take the plunge. After all, the cartridge was designed for black powder. All the "common" knowledge said to fill the case with FFG so there was no airspace and seat the bullet — so simple an Aggie could do it.

I went to the range and fired some of my smokeless loads to adjust my new Marbles tang sight — so far so good. Then I stuffed in some BP ammo and began to make smoke. Woo-Hoo, this is neat! Then I noticed that after less than a magazine of ammo, I couldn't even hit the dang paper. What the heck is going on here? I fired a few more, and it was even worse — couldn't even dignify it by calling it a "pattern." A cylinder bore shotgun would laugh at my "group." Disgusted, I went home cursing and scratching my head.

Upon arriving home, I tried to clean

the barrel, and could barely get a brush through it. When I did, I started pushing out long stringers of lead and took a couple of hours to get it clean. "Well, that sucks!" says I to the mouse in my pocket. This black powder just isn't worth it! How the heck did anyone ever hit anything with it?

Well, after calming down and doing more research, talking to a few people on forums, etc., I finally understood what had happened. I had violated several basic rules of assembling a reliable black powder load. Black powder does not play well with petroleum based compounds. In our case, this is the hard, crayon-like lubes used on regular commercial cast bullets designed for smokeless powder. Petroleum compounds when in the presence of combusting black powder will form the fouling from hell. This is what happens to most folks who try black powder for the first time, and it permanently sours them on it before they learn the cause.

Black powder requires a soft, non-petroleum based lubricant. There are lots of recipes out there if you want to make your own. Most involve beeswax, a light vegetable oil, and toilet

THE TIME IS RIGHT

Improve your skills with a **NEW** ProTimer from Competition Electronics!

PRO TIMER^{BT}

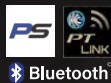

PRO TIMER



"My **Competition Electronics** ProTimer provides the feedback for a more effective training session at the range. I am proud to have **Competition Electronics** as part of my winning style for the last 25 years."

TODD JARRETT

Winner of dozens of major IPSC matches & multiple National and World Championships

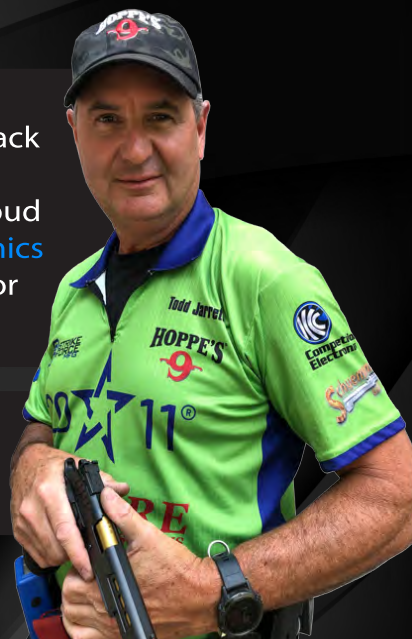

VISIT OUR WEBSITE FOR MORE INFORMATION

815.874.8001

www.competitionelectronics.com

bowl wax sealing rings. Or, if you're lazy like me, there are quite a few sold commercially. The one most commonly used was developed and is sold by Steve Garbe (multiple national champion BP single shot rifle competitor) and is called SPG (for Steven P. Garbe).

You need enough of this soft lubricant to keep the entire length of your barrel "wet" so you have a wet "lube star" on the end of your muzzle. By doing this, you keep the black powder fouling soft and each subsequent shot wipes the bore of the fouling from the previous shot — thus you have an equilibrium with one shot worth of fouling in the bore at any one time. With a properly assembled load achieving this, you can shoot indefinitely without cleaning the rifle.

Thus, we "shoot down" the myth that you have to clean the bore of a BP firearm after every few rounds fired. I'll shoot a complete 10- or 12-stage match and never clean my guns. I'll also shoot a complete long range match without cleaning.

BP ammunition works best with a soft bullet alloy, usually between 40:1 and 20:1 lead/zinc. This allows bullets to completely obdurate (or expand to fill) the rifling grooves, which prevents flame cutting of the bullet and lead deposits.

You need a bullet with large enough lube grooves to hold sufficient lube to keep the entire length of the bore wet. Many modern bullet molds don't have large enough lube capacity to do this.

These are the high-level basics of building good black powder ammunition. But let's address a few other misconceptions about shooting black powder.

Black powder guns have to be cleaned immediately after shooting — Well, yes and no. Yes, in that it is good to clean a gun that has fired black powder as soon as practical. However, the cause of corrosion is that black powder combustion products are hygroscopic

(they absorb water from the moisture in the air). Once they become damp, the sulfur that is part of the BP compound forms various acids (*i.e.*, sulfuric acid, etc.) and this causes the corrosion. HOWEVER... if you keep the gun in a climate controlled area with low humidity (your air conditioned or heated house) there is not enough humidity to cause a problem. While I don't like to make a practice of it, there have been occasions when my work schedule did not allow me to clean my gun for a week or more. I've had no corrosion and the bores are still bright and shiny.

Black powder is very hard to clean — This is probably one of the worst misconceptions out there. In fact, BP fouling is much easier to clean than smokeless powder fouling. The reason is simple — all of the fouling products are water soluble. The best BP lubricant/rust inhibitor I've found is Ballistol, which was developed by the Germans in the late 1800s for the purpose. Make about a 10:1 dilution of Ballistol in water and it forms a nice white emulsion that folks call "Moose Milk." Spray a little moose milk down the bore and run a few patches wet with moose milk down the bore — done. I guarantee you I can clean any of my guns with three or four patches and a pull of the bore snake. Wipe down the rest of the gun with the moose milk and let dry. The water dissolves the BP fouling and when it evaporates it leaves behind the Ballistol for lubrication and rust prevention.

NOW, A FEW RANDOM THOUGHTS...

As mentioned above, you do need a bullet of soft alloy designed to haul enough lube to keep the bore wet. Many people who get "hooked" by black powder end up casting their own to use — "Once you go black, you never go back!" However, there are several sources of bullets you can buy commercially. A few of these are Buf-

falo Arms, Montana Bullet Works, and Whyte Leather Works. Mark Whyte is really good to work with and casts Dick Dastardly's Big Lube bullets lubed with SPG at a very reasonable price.

It's pretty common for someone wanting to shoot "black powder" to buy one of the substitutes, like APP, Triple7, etc. The attraction is they can use the standard commercial cast bullets (don't need soft alloy and SPG), so it is viewed as simpler. There are, however, a couple of issues with these subs. They are more expensive than black powder. They are more corrosive than black powder. They are all based upon some type of organic acid as a key component, such as ascorbic acid. They MUST be cleaned immediately or they WILL corrode your guns. So if the real thing is less expensive and less corrosive, why would you use a sub?

Black powder is hard to find in metropolitan areas. Stores just don't stock it. This is unfortunately a result of storage requirements and insurance for compounds classified as explosive. This is largely why substitutes exist. They are not classified as explosive so can be stored and handled like conventional propellants. This is where the little brown truck is your friend. There are several good retailers that ship to your door — Grafts, Maine Powder House, Buffalo Arms, and my favorite, Powder Inc. The best pricing I've found is from Powder Inc and they are really nice folks to work with. Note that the prices quoted on their website include the Hazmat Fee as well as shipping, so it's an all-in price.

Okay, that's enough to give somewhat of a high-level overview of the care and feeding of black powder firearms. We'll continue in subsequent months with more specifics on how to load BP ammo for various purposes (cartridge revolvers, cap and ball revolvers, pistol caliber rifles, shotgun, big bore lever rifles, and big bore single shot rifles).

—I love the smell of sulfur in the morning!



After 30 years, Robert Arntzen is retiring from the target business. MADE, LLC will carry on the mission, delivering the same high quality AR500 steel targets you've come to expect from the best!

MADE TARGETS

AR500 STEEL TARGETS
HIGH QUALITY - PRICED RIGHT

Call: **833-GET-MADE**

Website: MADETargets.com

Email: sales@madetargets.com



PRESERVING WESTERN
MUSIC, POETRY & HERITAGE
OF THE AMERICAN WEST
FOR 35 YEARS

BECOME A MEMBER TODAY!



RECEIVE

THE WESTERN WAY

Official Quarterly Publication of the
International Western Music Association

FREE WITH MEMBERSHIP
OR SUBSCRIBE FOR ONLY \$22

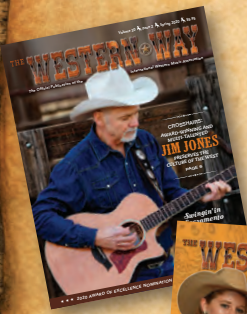

CONTACT THE IWMA FOR INFORMATION ON
HOW TO BECOME A MEMBER AND SUBSCRIBE TO WESTERN WAY

505.563.0673 • MARSHA@WESTERNMUSIC.ORG
IWESTERNMUSIC.ORG •  WESTERNMUSICASSOCIATION

HISTORY

MAXIMILIAN'S NOT-SO-EXCELLENT ADVENTURE IN MEXICO — 1863-1867

BY BIG DAVE, SASS #55632

In 1861, the year the American Civil War broke out, Mexico defaulted on its debts to Great Britain, France, and Spain. The three countries mounted a punitive expedition to force payment. Pretty soon, Great Britain and Spain withdrew, but the French troops remained. The Mexicans put up a stiff resistance and even defeated the French at the Battle of Puebla on May 5, 1862 (*Cinco de Mayo*) but they were steadily pushed back in subsequent months. By the spring of 1863, Mexico City and a large part of the countryside was occupied by French forces.

The French emperor, Napoleon III, embarked on an ambitious enterprise. He decided to install a monarchy in Mexico that would increase French prestige and profits. It would be unpalatable to the other European powers to set up a government with a Frenchman at its head, so he went shopping for an archduke in Austria.

The brother of Franz Josef, the Austrian emperor, fit the bill. This was Friedrich Maximilian von Habsburg, who was amenable to the venture. Although he was the Admiral of the Austrian Navy (if you haven't heard of it, there's a reason), Maximilian was bored with his privileged life. His wife Charlotte was positively delighted by the thought of becoming an empress. The scheme was sure to antagonize the United States, but so what? The U.S. was in the middle of a civil war and could not afford to interfere. There was a symmetry to the thing because in the 16th century, Mexico was originally part of the empire of Charles V, who was a Habsburg. Napoleon III could claim that he was restoring order to a chaotic land and at the same time deny he was setting up a puppet government.

To preserve the fiction that Emperor Maximilian was the result of the "people's will," a plebiscite was held in the areas



MAXIMILIAN VON HABSBURG WAS AN IMPRESSIVE LOOKING RULER. UNFORTUNATELY HIS IMPERIAL AMBITIONS IN MEXICO ENDED IN TRAGEDY.



CARLOTA, MAXIMILIAN'S WIFE, EVENTUALLY WENT INSANE.

occupied by the French troops. These were mostly in the large cities where the rich, famous, and reactionary Mexican citizens were congregated. They were sick of the disorder that had plagued Mexico for decades. The previous republic under Benito Juarez had, after all, caused the European intervention in the first place

by defaulting on its foreign loans. Juarez also had the gall to bring reforms that encroached on the privileges of wealthy churchmen. Why not try a monarchy again?

The problem was that the people in the countryside weren't necessarily enthusiastic about a foreigner who was propped up by French arms. Benito Juarez, who had fled Mexico City, was gone but not forgotten. Mexico is a vast country and he had plenty of places to hide. Juarez also had plenty of loyal, talented generals as well as potential recruits to ensure a protracted insurgency.

You can skip this part if you like, but it's helpful to know that in 1863, when Mexico City was in French hands, "Austria" included Hungary, the Czech Republic, Slovakia, Slovenia, parts of Italy, Poland, and other lands in eastern and southern Europe. Eventually the Austrian Empire became known as the Dual Monarchy, or Austro-Hungarian Empire. France was technically a constitutional monarchy but was called the Second Empire — Napoleon I had established the First Empire which vanished after his defeat at Waterloo in 1815. A series of political upheavals resulted in his nephew, originally Louis-Napoleon, becoming Emperor Napoleon III in 1852. (Napoleon II is too obscure and boring to write about.)

As long as I'm talking about family ties, it is worth knowing that the monarchies of Europe in the 19th century were so inbred that it even puts me, a native Kentuckian, to shame. This was especially true of the Habsburgs, who tended to produce offspring with long jaws and projecting lower lips. Some of them were almost un-presentable because in addition to being deformed, they were also intellectually challenged. However, it isn't fair to single out the Habsburgs for intermarrying. Victoria of England was the daughter of a German princess and had grandchildren that included Wilhelm II of Germany, Nicholas II of Russia, and George V of England. If the names of Victoria's descendants sound familiar, they were all players in WWI.

However, Maximilian von Habsburg was not in any way intellectually challenged. He was intelligent, decent, well-meaning, and naïve. His jaw was weird looking, but he grew a magnificent beard to hide it. He was married

to Charlotte of Belgium, who was related to Queen Victoria and was also sister to King Leopold II of Belgium. Charlotte's grandfather had been King Louis Phillipe of France who reigned from 1830 to 1848. Charlotte was especially keen to reestablish her own royal lineage. Unfortunately, this caused her to encourage Maximilian to embark upon a dangerous and foolhardy adventure. Even more tragic was the fact she encouraged her husband to remain in Mexico when it was obvious he needed to leave.

Maximilian and Carlota, as she was to be known in Mexico, left Trieste for Vera Cruz in April 1864. They arrived in late May and began an overland trip to Mexico City. Along the way, people cheered them and waved flowers and flags. While some of the goodwill was genuine, one gets the impression that in many cases the happy peasants had been "encouraged" by French troops. One of the carriages bearing Maximilian's staff encountered the bodies of deceased guerrillas during the journey. "See, this country is all but pacified," they were assured. Indeed, there was a plan to ambush Maximilian and Carlota, but it had been discovered and thwarted. "Not a thing to worry about, we have everything under control."

For a while, it looked that way. By April 1865, Juarez and his Republican forces had been pushed northward almost to the Texas border. Meanwhile, Maximilian and Carlota set up residence in Chapultepec Castle in Mexico City and established a European style court with all sorts of protocols and ceremonies. The Mexican conservatives, especially the high-ranking officials of the Catholic Church, were horrified to learn that Maximilian intended to bring reforms to his empire. In fact, he was beginning to resemble Benito Juarez in his attempt to modernize and secularize Mexico. This caused squabbling and division among Maximilian's supporters.

Unfortunately, Maximilian's army, which by now included Belgian, Austrian, Imperial Mexican, as well as French troops, could not completely suppress the insurrection. More bad news came when the American Civil War ended in April 1865. Secretary of State William Seward made it clear the United States was extremely displeased with the idea of a French client state in Mexico. Veteran troops under the command of American General Weitzel were sent to the Texas/Mexican border and began to harass the Imperial Mexican forces. Caches of weapons and ammunition were "lost" and conveniently "found" by Juarez' supporters. In France, enthusiasm for the Mexican venture began to wane. It was becoming exorbitantly expensive, among other things. The insurrection had to be put down quickly.

As veterans of Vietnam, Iraq, and Afghanistan will attest, putting down an insurrection is easier said than done. Time, terrain, and politics are on the side of the insurrectionists. Things get even more difficult when a major world power decides to provide support for the insurrection. If you prop up an unpopular regime, you had better steel yourself to be utterly ruthless. Unfortunately, ruthlessness is difficult to justify if you have any pretense of a conscience. Since insurrections usually involve atrocities on both sides, they result in a nasty cycle of retribution.

Maximilian tried to be ruthless, but it didn't really suit him, and he went about it in a half-hearted way. On October 3, 1865, he issued the Black Decree, which stated that



HELLFIRE AT BARRISTER'S JUNCTION

FOR AN APPLICATION AND MORE INFORMATION:
www.harvardghostriders.com

THE 2022 SASS MA-CT-RI STATE CHAMPIONSHIPS

June 3 - 5 2022

- 3 Stage Wild Bunch Match
- 3 Warm Up Stages
- Top Gun Team Shoot Off





www.uspsa.org

WANT MORE SHOOTING?

TAKE IT TO THE NEXT LEVEL.
You're already a skilled SASS competitor. So what about practical shooting? Practical shooting is the sport that simultaneously measures the ability to shoot rapidly and accurately with a full power handgun, rifle, and/or shotgun in a fun, fair, safe and competitive environment. Three elements - **power, accuracy, and speed** - form the three sides of the practical shooting triangle. Each match measures a shooter's ability in all three elements.

Get involved in practical shooting by visiting your local USPSA club match. To find one near you, use the "club finder" feature on our website at www.uspsa.org or call the USPSA office at 1-800-995-5646.



To become a member or find a club near you, check out www.uspsa.org or call us at **1-800-995-5646**

any Mexicans who took up arms against the Imperial forces would be executed if they did not immediately surrender. Once the decree was put into effect, Maximilian regretted it and began to issue pardons when he could. Nevertheless, an estimated eleven thousand Mexicans were executed over the next year. Disgusted, Maximilian rescinded the law in November 1866, but by then it was too late. The Black Decree had only made the resistance more committed. Predictably, Juarez applied the same principle to captured *imperialistas*.

By January 1866, Napoleon III had decided to extricate himself and his troops from the mess in Mexico. According to his plan, the first phase would occur in November 1866, the second in March 1867, and the final withdrawal was slated for November 1867. Maximilian was advised to abdicate and return to Europe. He was on the verge of doing so, but Maximilian's wife Carlota persuaded him to stay. A council of sycophants in Mexico City also urged him to fight on. So what if the French left? A new, "Mexicanized" army would be created which would fight on and eventually prevail.

Carlota went to Europe in July 1866

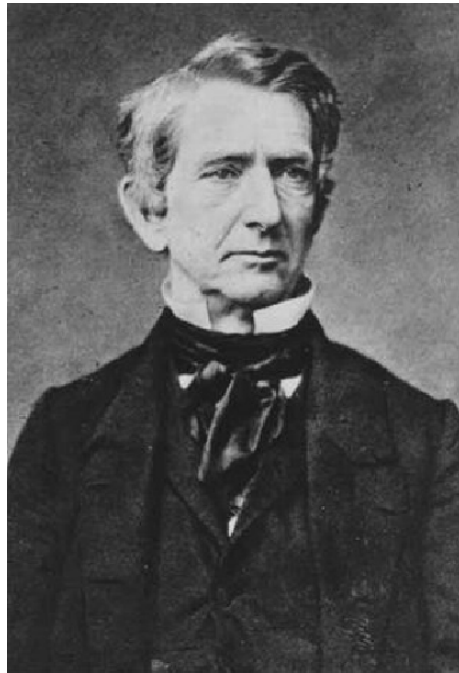

UNITED STATES SECRETARY OF STATE WILLIAM SEWARD WAS DETERMINED TO END FRANCE'S SECOND INTERVENTION IN MEXICAN AFFAIRS.

in hopes of persuading Napoleon III to change his mind about withdrawing or at least to continue funding the Mexican venture. Once she arrived in Paris, it was almost comical how Napoleon tried to avoid her. Carlota was quite determined, and she eventually gained an audience

with the French emperor. There were tears and excuses from Napoleon (who was suffering from kidney stones), but he stood firm about his decision. After an incisive remark, Carlota left for Rome in hopes of enlisting the diplomatic skills of Pope Pius IX. After all, she and her husband were Catholic monarchs and Pius had given his support to the venture in the first place.

That didn't work out well either. Carlota had suffered headaches and episodes of "melancholia" for a long time. The stress of recent events led her to a complete nervous breakdown. She became convinced that someone was trying to poison her. The pope was sympathetic but could promise nothing. Indeed, as it became obvious that she was spectacularly unhinged, Pius IX avoided Carlota as though she had the plague. Whenever she saw him, she insisted that he taste her food to thwart her would-be assassins. The beleaguered pontiff was reduced to hiding in the unused rooms of his own palace. Eventually Carlota was bundled off to Trieste where she was put under the care of an "alienist" or psychiatrist. She never saw Maximilian or Mexico again.

In Mexico, the withdrawal of



SASS STARTER KIT
\$299.95



Mernickle Custom Holsters
"Helping to Create World Champions Since 1975."
Follow us on [f](#) [@](#)



HOWLIN WOLF SIGNAURE SERIES HIGH PERFORMANCE SERIES W/FULL BASKETWEAVE
\$599.95



Artistry In Leather



HIGH PERFORMANCE SERIES
419.95



MANY ACCESSORIES



FULL CARVE RIGS STARTING AT
\$899.95



THE FAMOUS FRENCH PAINTER EDOUARD MANET DEPICTED MAXIMILIAN'S EXECUTION. HE WAS ORIGINALLY UNABLE TO EXHIBIT THIS PAINTING BECAUSE IT WAS AN EMBARRASSMENT TO THE SECOND FRENCH EMPIRE.

French troops accelerated. Napoleon III rightly anticipated a growing threat from Prussia and its brilliant statesman, Otto von Bismarck. France couldn't afford to squander its manpower by prolonging a doomed venture in the New World. In addition, U.S. Secretary of State Charles Sumner continued to apply diplomatic pressure. In early 1867, Marshal Achille Bazaine, the commander of the French army in Mexico, practically begged Maximilian to abdicate. Unfortunately, Maximilian chose to stay and took personal command of the imperial forces. By March 11, 1867, the last French troops departed for their homeland.

As the French scaled back their presence in Mexico, Juarez' army retook city

after city. The Imperial Mexican Army, reinforced by various European volunteers (as well as some ill-advised former Confederates) was demoralized, underfed, underpaid, and poorly armed. Maximilian and those troops who remained loyal were holed up in Queretaro, about 100 miles north of Mexico City. On May 15, a turncoat Mexican officer opened the gates of Queretaro to the Republican forces. Maximilian and two of his top generals were taken prisoner.

A trial was held the following month. The outcome was predetermined. Maximilian, Generals Miramon and Mejia were found guilty of bearing arms against the Mexican republic and sentenced to death by firing squad. Ironically, Maximilian and his

top generals were sentenced to death for the same offences outlined under his own Black Decree, except this time the tables were turned. There were appeals to commute the sentence from all over the world, but President Juarez was unmoved. An example had to be made so that future adventurers would not threaten Mexico's sovereignty. As one historian observed, Maximilian signed his own death warrant by signing the Black Decree.

On June 19, 1867, Maximilian and his two commanders were executed by firing squad. All of them died bravely. Death was instantaneous for the emperor and Miramon, but Mejia flopped around a bit and had to get a *coup de grace*. Maximilian's body was shipped to



EVERY GOOD STORY NEEDS A VILLAIN. IN THIS ONE, IT IS NAPOLEON III OF FRANCE. HE SOUGHT TO INSTALL MAXIMILIAN AS EMPEROR OF MEXICO AND THEN ABANDONED HIM WHEN THE GOING GOT TOUGH.

Europe and interred in Vienna.

He would have made a good ruler had he come to power under different circumstances. Maximilian truly cared about his adoptive country and its people. There wasn't a whole lot of difference between the future he envisioned for Mexico and the future Juarez wanted. Tragically, he was installed and propped up by a foreign power. That was impossible for most Mexicans to overlook. Once that power withdrew, he was doomed.

Carlota, Maximilian's unfortunate spouse, was cursed with a long life. She never fully regained her composure. Not long after Maximilian's death, she was persuaded to return to Belgium to live

with her brother, King Leopold II. Her husband's fate had been kept from her so she would agree to the move. Once she learned what had really happened, she became even more unstable. Sometimes Carlota would behave in a calm, lucid manner, but at other times she would shout, weep uncontrollably, and break whatever breakable objects were available. At other times she would tear her clothes off and proceed to beat herself with a riding crop. Understandably, she was kept out of the public eye. She finally died in 1927 at the age of 86.

It is with some satisfaction that I can relate what happened to Napoleon III, the man whose vanity and ambition had instigated this entire mess. Things were changing in continental Europe regarding the balance of power between France and Prussia, the largest German state. Otto von Bismarck, the chancellor of Prussia, had ambitions to unite the various German states under Prussian hegemony. While Napoleon III had his dalliance with Mexico, Bismarck had engineered a series of conflicts with Austria and Denmark that had maneuvered the northern German states into a military and economic alliance with Prussia. The southern German states, most notably Bavaria, had so far kept out of the alliance. France was dead set against German unification and rightly considered Prussia to be a threat.

Bismarck hoped to lure France into a war that would force the holdout German states into an alliance that would ultimately result in German unification.

In July 1870, Bismarck edited a telegram from King Wilhelm I of Prussia to the French ambassador that made it look like Wilhelm was insulting French honor. The plan worked — the French press howled for revenge and Napoleon III was maneuvered into a war for which he was ill-prepared. Prussia, on the other hand, had developed military plans years in advance for this very contingency. To make a long story short, France was defeated in less than a year.

Napoleon had to abdicate, France had a mini civil war, and the 3rd French Republic was eventually established. Exiled to England, Napoleon III died of kidney failure in 1873. He is remembered as *Napoleon le Petit* because he failed to live up to his namesake. The epithet fits,

Bibliography

"Carlota of Mexico." Wikipedia, Wikimedia Foundation, 24 Feb. 2022, https://en.wikipedia.org/wiki/Carlota_of_Mexico.
 "Emperor of Mexico Executed." History.com, A&E Television Networks, 3 Mar. 2010, <https://www.history.com/this-day-in-history/emperor-of-mexico-executed>.
 "Ems Dispatch." Wikipedia, Wikimedia Foundation, 22 Feb. 2022, https://en.wikipedia.org/wiki/Ems_Dispatch.
 "Maximilian I of Mexico." Wikipedia, Wikimedia Foundation, 24 Feb. 2022, https://en.wikipedia.org/wiki/Maximilian_I_of_Mexico.
 McAllen, Amberson Mary Margaret. Maximilian and Carlota: Europe's Last Empire in Mexico. Trinity University Press, 2015. "The Mexican Campaign, 1862-1867." Napoleon.org, <https://www.napoleon.org/en/history-of-the-two-empires/timelines/the-mexican-campaign-1862-1867/>.
 "The Mexican Campaign, 1862-1867." Napoleon.org, <https://www.napoleon.org/en/history-of-the-two-empires/timelines/the-mexican-campaign-1862-1867/>.
 "Napoleon III." Wikipedia, Wikimedia Foundation, 7 Mar. 2022, https://en.wikipedia.org/wiki/Napoleon_III.
 Parkes, Henry Bamford. A History of Mexico. Houghton Mifflin, 1990.
 "Second French Intervention in Mexico." Wikipedia, Wikimedia Foundation, 8 Mar. 2022, https://en.wikipedia.org/wiki/Second_French_intervention_in_Mexico.
 Smith, Daniel Malloy. The American Diplomatic Experience. Houghton Mifflin, 1972.

Stocking Dealer Henry and Cimmaron Firearms



**OVERALL NATIONAL &
OVERALL WORLD CHAMPION**



EVIL ROY PISTOL—TUNED AND MATCH READY
1873 RIFLES—TUNED AND SHORT STROKED OR STOCK
SASS RUGER VAQUERO—TUNED & JEWELED
CONSEC S/N PAIR
SHOOTING CLASSES IN TEXAS —BY APPOINTMENT
EVIL ROY TRAINING DVD'S

NEW IMPROVED EVIL ROY LEATHER LINE

New fully steel/leather lined holsters keep the holsters rigid and adjustable for tension for years. Compress the holster for a slightly tighter fit or expand it for a looser fit. Allows a shooter to choose tension low on the barrel or on the cylinder. The higher 1880's style sides make for a longer funnel for reholstering your firearm and for better retention. The front of the holster is cut down and the trigger guard exposed for a fast draw. Available in strong side, cross draw or muzzle forward.

Made by Ted Blocker Holsters, Quality Leather Products for 40 years.
 Free Shipping on orders over \$250, Lower 48 states



Check our **NEW WEBSITE** for pricing, additional firearms and other products.

WWW.EVILROY.COM
evilroy@evilroy.com (970) 385-4141

POEMS

ALONE BY THE CAMPFIRE

By Deslaredo, SASS #91085

Alone by the campfire The Undertaker sat
With his Undertaker attitude and his Undertaker hat
He watched the burning logs disintegrate and fall
Then memories came drifting back of a cowboy riding tall.

Into the red horizon the cowboy disappeared
The prairie dogs were nervous and the lone coyote sneered
The Undertaker stoked the fire as he remembered the nights
When he held his favorite rifle and had destiny in his sights.

Alone by the campfire The Undertaker smiled
He'd seen it all and done it all, but he was still runnin' wild.
He watched the flames flicker as they licked the moonlit air.
As the history of his past took him back to who knows where.

Into the solemn darkness his mind took him away
To a land of smoky saloon halls where all were led astray
To a land where bootleg whiskey was the flavor of the night
Where everything looked wrong but everything was right.

Alone by the campfire The Undertaker knelt
With a shotgun by his side and a pair of six guns on his belt
The flames began to rise as the wind began to howl
And then was heard a hoot. It was a hoot from a distant owl.

Into the burning embers he stared with blood shot eyes
He could see it all behind him. All the lows and all the highs
But he knew where he belonged and he knew where he was at
So alone by the campfire The Undertaker sat.



THE OUTLAW

By Deslaredo, SASS #91085

He dresses like an outlaw from his toes up to his head
He fills the air with danger, catastrophe and dread
He wears his guns down low but he's always on a high
And if you give him any static, you will more than likely die.

His hat is black with a snakeskin band and his boots are weathered and old
His brow is wrinkled from a thousand frowns and his eyes are sharp and cold
His hands are quick but his pulse is slow for his heart just moseys along
His mind is forever restless and free like the beat of an outlaw song.

His past is always chasing him no matter where he goes
But he manages to keep ahead of it as long as he follows his nose
He sleeps with one eye open. He's always ready to react
His lead is always loaded and his powder always packed.

He normally tries to avoid a fight but sometimes it doesn't work
Because he always seems to come across some empty headed jerk
But he doesn't let it faze him, he confronts them and makes his play
Sooner or later they all realize they've gotta get out of his way.

Yes he lives just like an outlaw and he's always on the prowl
He prefers to keep good company with the eagle and the owl
If he ever gets you in his sights, it will chill you to the bone
The best thing you can ever do is leave him well alone.

If you see him walkin' down the street, ya better give him a wide berth
For if he sets his eyes upon you, your days are numbered on this earth
An aura of death surrounds him and his vision is off the map
You better steer clear of The Outlaw because he's one hell of a deadly chap.



PRODUCT REVIEW



AUTHOR'S KIRST/PIETTA 1860 SABER RIVER AND AVENGING ANGEL.

KIRST KONVERTERS PART IV EMF/PIETTA 1860 SABER RIVER .45 COLT KONVERTER PROJECT

BY TUOLUMNE LAWMAN, SASS #6127

It is no secret to any of my CAS friends or our readers that I am huge fan of the metallic cartridge conversion revolvers of the early West. It is also no surprise to them that I am a huge fan of all of Tom Selleck's Westerns, not the least of which is his outstanding 1997 classic, *Last Stand at Saber River*. Here is a great synopsis of the plot from IMDB (International Movie Data Base):

"As America recovers from the Civil War, one man tries to put the pieces of his life back together but finds himself fighting a new battle on the frontier. [Paul] Cable is an embittered Confederate soldier who returns from the war to reclaim his Arizona homestead from rebel pioneers who sympathize with the Union war effort. Desperate to rebuild the life he once knew, Cable ultimately joins forces with Vern Kidston, his Union adversary to make a last stand for the one thing worth fighting for — his family."

Paul Cable (Selleck) returns to his home in Arizona. His father in law, James Sandford (Harry Carey) is an established and prolific frontier gunsmith. Cable's wife, Martha Sandford

Cable (Suzy Amis), is also an accomplished "gun plumber." She gives her husband a custom cartridge conversion 1860 Colt, which now uses metallic cartridges and has an ejector. It has ivory grips and is engraved. The revolver that was actually used in the movie is a Kenny Howell custom 1860 Richards Type I conversion. As the movie is about 1865/66, that was at least five years too early for a Richards conversion to be correct. It was not, however, too early to be a private conversion. These private Long Cylinder Conversions (LCC) were beginning to proliferate about the same time (around 1866 and 1867) that Remington New Model Army revolvers (aka 1858s) were being factory converted to five-shot .46 rimfire caliber under license

of S&W's Rollin White patent for bored through cylinders. The private conversions, of course, were unlicensed, but it was impossible to enforce these private conversion patent violations in the far reaches of the American Frontier.

Many Remington and Colt revolvers were privately converted by very talented frontier gunsmiths like Saber River's fictional James Sanford. The most common cartridge used for the conversions was the .44 Henry rimfire, but others were converted to .38 or .46 Rimfire. Later, private conversions used the .44 Colt cartridge, which was designed for the Colt Richards conversions. There are even some samples of 1860 Colts that have been found that were converted to five-shot cartridge revolvers in .45 Colt! In the 19th Century, weapons were not discarded just to upgrade to the next fancy firearm. Often they remained unchanged, or were retrofitted with improvements (like a cartridge conversion) and still used for many years. I remember reading (about 20 years ago) that one member of Butch Cassidy's post-1900 Hole in the Wall Gang was recorded to have still carried a Remington New Model Army in .46 rimfire. If it still worked well, they didn't replace it just because something newer came out, unlike today in our disposable economy.

The .46 short rimfire was generally available in two loadings. Remington's loading had 20 grains of black powder under a 227-grain conical bullet. Winchester's loading of the cartridge, on the other hand, was 27 grains of pow-



TOM SELLECK'S KENNY HOWELL-MADE CUSTOM 1860 .44 COLT FROM LAST STAND AT SABER RIVER.



PERIOD 5 SHOT 1860 LONG CYLINDER CONVERSION, POSSIBLY .46 RIMFIRE (FROM THE WEB).

der and a 230-grain bullet. Both the Remington and Winchester versions of the .46 rimfire were really good fight stoppers. The Winchester loading, however, was the superior of the two, having more punch than the more common .44 Henry rimfire cartridges used in other

conversions. The Winchester loading had virtually identical performance to the later (1875) developed S&W .45 Schofield centerfire. It was also the equal of the 1902 developed, 230-grain .45 ACP cartridge that is still alive and well 120 years later, and is arguably the

www. **Rim Rock Bullets.net**

Top Shelf Cast Lead Bullets

Prices subject to change without notice.

- This is a good cross reference of the bullets we offer. We have about 144 sets of molds with new molds coming.
- 16 employees working 10 hr. a day shifts 4 days a week with 9 casters, 6 auto lubers and 12 star lubers gas checking every day.
- We have bullets made with five different alloys that we order 40,000 - 60,000 lbs at a time a mixed per our set alloys.

Now in our new state-of-the-art 12,000 square foot facility!

Rim Rock Bullets
 35675 Minesinger Trail • Polson, MT 59860
 (406) 883-1899 • Mon-Thurs, 8AM-5PM MST
 sales@rimrockbullets.net

Non Gas-Check			Gas-Check		
.25	85 GR.	RNFP/500	.25	120GR.	RNFP/100
.30	115 GR.	RN/500	.30	125 GR.	RNFP/100
.30	165 GR.	RNFP/500	.30	155 GR.	RNFP/100
.32-40	170 GR.	RNFP/500	.30	170 GR.	Silhouette/100
.458	300-525GR.	/100	.32	115 GR.	RNFP/100
			.338	200 GR.	RNFP/100
			.348	225 GR.	RNFP/100
			.358	230 GR.	RNFP/100
			.458	405 GR.	RNFP/40
			.458	430 GR.	RNFP/40
			.458	500 GR.	RNFP/50
			.500	540 GR.	SP/100

Our Online Catalog Has Over 100 Different Bullets!
Everything is in stock | Specialty Sizing Available
Brinell Hardness from 4-22



KIRST HAND-ENGRAVED SABER RIVER KONVERTER KIT.

finest self defense handgun cartridge ever developed.

I started shooting SASS® matches in 1994. Since about 1996, I have been a staff writer and firearms evaluator for *The Cowboy Chronicle*. This has allowed me the unique opportunity to shoot most of the Uberti, Pietta, Rossi, Ruger, Henry, and Armi San Marco replicas through the years. I have also used many original Colts, Winchesters, Smith & Wessons, and Marlins in my years in SASS. With all of the revolvers I have had access to and used over the last 28 years, what I now use for SASS main match revolvers may surprise you!

While I use a RIA 1911A1, 1894 Marlin Century Limited, and an original 1897 Winchester for Wild Bunch matches, my standard SASS main match pistols are all Kirst-Konverted Pietta black powder revolvers that I converted myself. Two .45 Colt 1860s, a .45 Remington 1858 Remington, and a Colt 1851 in .38 Colt are my go to pistols. I feel that these “private conversions” of mine are truly in keeping with my

persona of an 1867/1868 Lawman in the California Gold Fields. His revolvers are private conversion, five-shot, in .46 rimfire. These are paired with an 1860 .44 Henry he carried during the Civil War and a 12 gauge hammered coach gun. Since .46 rimfire for revolvers and .44 rimfire for the rifle are not exactly feasible for SASS main match firearms, I use .45 Schofield in the revolvers and .44-40 in my HRA 1860 Henry.

PIETTA 1860 KIRST SABER RIVER

Of the above, my absolute favorite SASS revolver is my Pietta 1860 Colt, Kirst-Konverted Saber River. (Though my three-inch Kirst/Pietta Avenging Angel is a REAL close second!). The sleek and beautiful eight-inch barreled 1860, with its beautifully engraved cylinder and ejector rod and faux ivory grips, points like few other revolvers I have tried. Besides being a beauty, to me it seems it shoots so well you have to try to miss a plate! In fact, in the past couple years I have been using my Kirst/Pietta Saber River, I have never missed a

steel plate target at a SASS match.

I started with a Pietta .44 Colt 1860 revolver with an eight-inch barrel from Debbie Sims at EMF. I obtained the .45 Colt/Schofield “Saber River” edition Konverter kit from Walt Kirst and VTI. I finished off the revolver with some nice one-piece, faux-ivory grips from Get-a-Grip on eBay (for about \$70). Unlike the standard 1860 Konverter kit with its smooth cylinder and Richards-style ejector rod assembly, both the cylinder and ejector rod assembly for the Saber River kit are hand-engraved in a pattern that closely replicates the engraving on the Kenny Howell custom 1860 used in *Last Stand at Saber River*. I finished off the package with a period correct Texas Jack’s Slim Jim holster from Cimarron Firearms.

KIRST KONVERTERS

Walt Kirst has been interested in Cartridge Conversion revolvers for many years. A talented machinist and inventor, he had done some custom conversions of percussion revolvers. More than 20-plus



DREMEL DRUM USED TO CUT LOADING CHANNEL IN RECOIL SHIELD.



LOADING CHANNEL COMPLETED AND CONVERSION RING AND GATE INSTALLED.

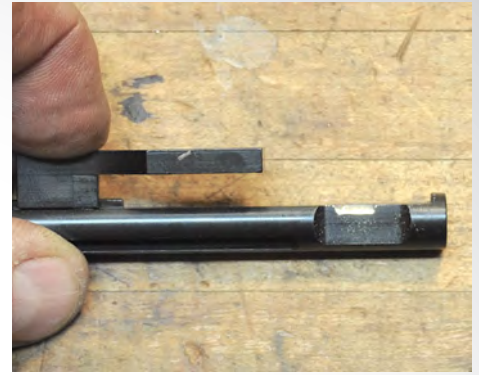

NOTCH CUT IN EDGE OF FLAT ON BOTTOM OF EJECTOR ROD TO ALLOW CLEARANCE FOR WEDGE RETENTION SPRING.

years ago, he came up with the idea of a drop-in cylinder to convert an 1858 Remington into a .45 cartridge revolver. His initial design had a solid back plate with a single firing pin and a five-shot cylinder. A little later, he came up with a gated version that required a channel to be cut in the recoil shield. His current version has a spring loaded loading gate like period "Thick Plate" Remington conversions. Kirst still offers a non-gated "Pale Rider" 1858 unit.

Walt eventually also came up with a five-shot .45 Colt/Schofield conversion cylinder for the 1860 Colt clones. Like the later production 1858 Konverters, these are gated and require milling or grinding out a channel in the Colt recoil shield for the cartridge to load and eject through. The Saber River is an engraved version of this gated 1860 Konverter. Note, these gated 1860 Konverters can still be used without modifying the recoil shield. You simply remove the cylinder to load and unload it, as you would with the 1858 Pale Rider, non-gated Konverter.

Kirst Konverters are SASS legal, even though they are five-shot cylinders. In the case of the 1860 Konverter, you simply lower the hammer down so the firing pin is between two chambers when not being fired or in the holster. In the case of the 1858 Konverters, there is a designated "safety chamber" area between two of the chambers to rest it. When you cock the hammer, the cylinder rotates to the first cartridge and locks in place for firing.

Some basic information from the Kirst Konverter Website

- Made from strong, heat-treated 4140 steel or stainless steel.
- CNC machined, blued or polished, and assembled in the U.S.A.

- No F.F.L. paperwork is required to purchase one.
- Double or triple the calibers of your percussion revolver.
- Increase your shooting time while decreasing loading time.
- Kirst offers matching ejectors for many of our Konverters.

The Kirst unit is "drop in" in the .45 and .38 versions of the 1858 and, in the six-shot Pietta 1851/1861s. In the five-shot .45 caliber 1860 versions it may require some minor fitting to cycle correctly. (Uberty's, especially recent ones, can have some timing issues because of Uberty relocating the cylinder hand farther from the arbor than older ones.)



AUTHOR WITH HIS KIRST/PIETTA SABER RIVER AND HRA 1860 HENRY.

KIRST INSTALLATION

With the gated Konverters, I found it was not hard at all to grind the channel in the recoil shield of the Pietta revolvers. I disassembled the revolver and placed the Kirst gated recoil shield in place. I opened the gate and painted the area on the recoil shield that needed to be removed with black marker. Removing the recoil shield left a black shadow that guided my grinding. Don't worry, the placement of the channel does not have to be exact. There is plenty of tolerance in the alignment if you don't get it exact.

I used a Dremel grinder with a 1/2-inch sanding drum and began to slowly grind. It took about five drums, but I changed when the grinding slowed. I started with a coarse 60-grit drum. When I got close, I switched to a 120-grit one for a smoother finish. Periodically I would install the cylinder and recoil plate and attempt to eject an empty shell. After about 45 minutes, it was done. I polished the ground out area with fine emory cloth, then hit it with Birchwood Casey cold blue while it was still warm. It is actually surprisingly easy if you take your time and don't get impatient. It is a good idea to cover the lower part of the receiver below the recoil shield with tape, in case you slip (I found this out the hard way on the first one I did).

From start to finish was less than an hour and a half. In the end, I had an 1860 Colt cartridge revolver, chambered for .45 Colt/Schofield cartridges. Even though the percussion cylinder is six-shot and the .45 Colt/Schofield conversion cylinder is five-shot, the timing with the conversion cylinder was perfect. Kirst has maximized the angles of



AUTHOR'S KIRST/PIETTA .45 CALIBER REMINGTON NMA (1858) KONVERSION.

the indexing star on the rear of the cylinder to achieve enough rotation for the five-shot cylinder to rotate into place.

The only fitting I had to do on my 1860s was the wedge. Even with the percussion cylinder, when the wedge was inserted far enough for the retention spring to engage on the right side of the wedge hole, it was too tight to allow free rotation. This is not an uncommon occurrence on all 1851- and 1860-based revolvers, whether made by Pietta or Uberti. It is just a part of the 180-year-old "open top" design that goes back to the 1836 Patterson.

Also, when using .45 Schofield rather than .45 Colt it can be tighter because of the thicker Schofield brass. Fortunately, it is very easy to fix on any "open top" design. I looked and the rectangular hole in the barrel arbor was

smaller than the frame hole, and was pushing the muzzle too tightly against the face of the cylinder. I removed a few swipes at a time from the front of the wedge (about 1/64-inch) with a fine file until the Kirst cylinder turned free. I made it where the wedge now inserts far enough for the wedge spring to grab the outside edge of the notch, retracts with finger pressure, and allows free rotation of both cylinders.

To finish, I installed the Richards-style ejector rod assembly. Unlike the original one-piece milled assembly that the Colt Richards conversions used, this is a two-piece unit. Simply remove the rammer assembly, re-install the rammer screw, and tighten the assembly with the supplied set screw for a perfect rattle free fit. One modification I did was to cut a small notch in the edge of

the flat spot on the bottom of the ejector rod that the wedge slides through (see picture). This allows clearance for the wedge retention spring to grab the edge of the rectangular hole in the barrel web that the wedge passes through.

Loading the Kirst 1860 is the same as loading a Colt Single Action Army. Pointing in a safe direction, cock the hammer to the first notch. This allows the cylinder to rotate freely in a clockwise direction. Open the loading gate and line up a chamber in the cylinder with the loading channel and insert cartridge. Repeat until all five chambers are loaded, then rotate the cylinder until you can lower the hammer where the firing pin rests between two cylinders. To unload, you repeat the process. With my loads, the cases fall out when you tip the muzzle up and rotate the cylin-



AUTHOR'S KIRST/PIETTA .38 LONG COLT 1851 NAVY KONVERSION.

der slowly. If they stick, the Colt Richards style ejector rod assembly is used to knock the empty cases out.

HOW DOES IT SHOOT?

As with all 1860 percussion revolvers, the sight picture on my Saber River is rudimentary. That is because the rear sight notch is a very small “V” cut in the front nose of the hammer and the front sight is a short, tapered brass blade. I slightly enlarged the notch with a triangular machinist’s file to improve the sight picture.

The load I use in my main match pistols is loaded in a .45 Schofield case using a 200-grain RN, hollow based bullet (that I also use in my 1911 for Wild Bunch). The load is 5.0 grains of Trail Boss. It is a stout load, though the 1860 grip handles it with ease. With this load, the Saber River 1860 shoots dead center, but about three inches above point of aim at ten yards, using a traditional two-hand hold. As I have said before, this is very common with all of the Colt percussion revolvers, including originals. I aimed at a six o’clock position on a four-inch bulls-eye and hit about three inches above in the black, making a nice three-inch cluster. At a match, I would use a “low, just below dead center hold” and generally hit the center of the target.

I also used some excellent Black Hills and HSM factory .45 Schofield ammunition in the Saber River. It printed to almost the same POI as my handloads. The Black Hills and HSM were not as stout as my loads, and actually grouped a bit better than the Trail Boss hand loads I use.

Kirst Konverters are made to be used with either black powder loaded ammo or “Cowboy Action” loads that approximate BP loads (under 1,000 fps). DON’T shoot Buffalo Bore ammo or any +P cartridges from a Kirst Konverter.

CONCLUSION

Much of the early Old West was dominated by percussion revolvers like the 1851 and 1860 Colts. Many of these were converted to cartridge revolvers, both by the factories and talented frontier gunsmiths. The importance of these early metallic cartridge firearms in the settling of our frontier in the last 30 years of the 19th Century can not be overstated. Whether you are a Cowboy Action Shooter™ interested in recreating a persona from the early West or just a shooter that enjoys classic looks, the Pietta 1860 Colt with a Saber River .45 Colt/Schofield caliber Kirst Konverter is a good choice. After all, Tom Sell-eck has pretty good taste in his choice of period correct firearms for his westerns, and the Saber River Colt I am told is one of his favorites.

For me, there is also a certain pride in creating your own cartridge revolver from percussion, just like those gunsmiths of the Old West.

CREDITS

The Pietta 1860 Army revolver is from is from Debbie Sims at EMF & Co. — 800-430-1310 or check their web-site, <https://www.emf-company.com/>

The five-shot .45 Colt/Schofield conversion cylinder is from Walt Kirst at Kirst Konverters. Check out their web page, <https://kirstkonverter.com/>

—Tell them Tuolumne Lawman sent you.

DIXIE

Gun Works, Inc.

We're living America's history. Everyday.

The blackpowder era is proudly woven into our rich American tapestry. And today, thousands of blackpowder enthusiasts—from primitive and military re-enactors to modern hunters and competitive shooters—keep the tradition alive. Everything you need to take part is right here in the **2022 DIXIE GUN WORKS'** catalog—the world's largest selection of blackpowder replica arms, accessories, antique parts, muzzle-loader hunting and sport shooting equipment.

PROFESSIONAL SERVICE AND EXPERTISE GUARANTEED

**ORDER TODAY!
STILL ONLY
\$5.00**

VIEW ITEMS AND ORDER ONLINE!
www.dixiegunworks.com
Major credit cards accepted

FOR ORDERS ONLY (800) 238-6785



DIXIE GUN WORKS, INC.

1412 W. Reelfoot Avenue
PO Box 130 Union City, TN 38281
INFO PHONE: (731) 885-0700 FAX: (731) 885-0440
EMAIL: info@dixiegunworks.com



WEAVER

LEATHER SUPPLY

QUALITY 45 YEARS STRONG

You'll find the right supplies for all your projects with Weaver Leather Supply. Over 45 years of manufacturing experience goes into hand selecting the finest leather, webbing, hardware, tools, saddlery supplies, leather care, machinery and more to ensure successful results for professionals and hobbyists alike.

Wholesale: shop.weaverleather.com Retail: weaverleathersupply.com
800-932-8371

TRAILMARKERS

HAPPY TRAIL MARKER THE APACHE KID WHO KNEW HE WOULD REACH 82?!

BY GREY FOX, SASS #223, LIFE, REGULATOR, HALL OF FAME

Happy Birthday to my dear friend The Apache Kid (SASS #37). Our first meeting with the Apache Kid at the beginning of our second END of TRAIL, Coto de Caza, California was in the summer of 1985.

Miss Mary Spencer (SASS #55147, Life, Regulator) and I were walking toward the gun clubhouse at the Coto Range. It was a surreal moment of kindred spirits, the Kid dressed in his Apache finest, wearing a long bear hide coat, and I dressed in my Northwest Canadian best, Canadian peak hat, canvas coat with shearling lining and collar, shotgun chaps, and O.K. spurs, approaching the fully kitted Apache Kid. We spotted each other and became instant friends.

The Apache Kid (Reg Byrum) a man of adventure first in the military then a motorcyclist, an accomplished



horseman, star of Wild West Shows, member of the Red Sash Gang in the movie Tombstone, mounted shooting competitor, and dedicated member of the Single Action Shooting Society!

It is difficult to express the amount of joy having known the Kid for 37 years, herding cattle, riding at high speed, shooting our pistols to rob stage coaches during Wild West Shows, performing street theatre with various theatrical troupes and competing in SASS matches!

There are not many who can relate to a true life of high adventure.

Reg Byrum born February 4, 1940 having turned 82 February 4 2022, I wish the Apache Kid many more years of adventure.



ADVERTISE

In
THE Cowboy CHRONICLE

Each issue of *The Cowboy Chronicle* has a readership more than 75,000 and contains articles on Cowboy Action Shooting™ and the laws that affect it, as well as information on SASS® monthly and annual events.

The Cowboy Chronicle is published quarterly, with printed issues in January and July, and digital-only issues in April and October. Ad deadlines fall roughly two months in advance of each issue. Visit www.sass-net.com/chronicle or call Square Deal Jim for more information and for exact deadlines.

ALSO AVAILABLE — You can purchase ad space, banners, buttons, and badges on the SASS website.

If you need assistance producing or laying out your ad we can help.

**CALL SQUARE DEAL JIM
TO RESERVE YOUR SPACE TODAY
(410) 531-5456**

WILD BUNCH

ARIZONA WILD BUNCH STATE CHAMPIONSHIP 2021

BY FREDERICK JACKSON TURNER,
SASS #28271

I'm tapping this out before catching up on my sleep after a whirlwind weekend at Cowtown, AZ, having just blazed through the fun and challenging Arizona Wild Bunch State Championship. For this wandering Cowboy, pulling into Cowtown is always a bit like coming home. I've gone there so many times for Winter Range warm-ups, the excitement builds the moment you turn off the highway. With my trusty 1911 and a ton of ammo in the back of my Jeep, it was good to be "home" on Feb 13 and 14, for the 2021 Arizona State Wild Bunch Championships.

Match directors Zona (SASS #54629) and Barbwire (SASS #10179) did a great job crafting this match, with reasonable and occasionally exacting target placements, interesting and sometimes brain-teasing sequences, plenty of targets, and lots and lots of variation. No two stages were the same, there was plenty of variety, and more 1911 shooting than you could shake a Colt at. Even the weather was Arizona perfect!

From the first stage, I liked the Arizona stage protocols. Every stage was begun the same, with hand on gun. No interpretation of this is required, do so safely, and just like you might start a real gunfight. Every stage also had multiple shooting positions and the gun order was left up to the shooter. You flew, or crashed, based on your own decisions.

And SO MUCH steel! Cowtown has been around for quite a while, and it shows in their vast array of targets. There were 10 complete and unique stages, each with plenty of targets to engage. I counted, on various stages, in addition to targets of every size and description, four dueling trees, a long range full-sized steel silhouette, discs, squares, rectangles, coffins, cowboys, swingers, and one stage that contained what I dubbed "Lucifer's Rack." This



LADIES LIKE WILD BUNCH!



HOW IT'S DONE — FINGER OFF THE TRIGGER, GUN ON THE WAY DOWN TO THE TABLE, SHOTSHELL STILL IN THE AIR...

infernal contraption consisted of nine steel targets in strings of three across, with reasonably-sized targets on the top, smaller targets on the bottom, and three teeny little suckers in the middle. Instructions were simple — double tap the good sized circles on either end, sweep the three, and double tap

the larger targets on the end. It was like driving a racetrack — mash the accelerator for the straights but throttle waaay back for the curves, then hit the gas again. Fun and challenging stuff! I asked Zona how much ammo I would need. He answered, "87 rifle, 56 shotgun." "How about pistol?" He chortled.



THE CALIFORNIA CONTINGENT IS ALL SMILES! FROM LEFT: TULLY MARS, WHIRLWIND WENDY, MS. PENNY ANTE, AND FREDERICK JACKSON TURNER.



MS. PENNY ANTE READY TO START, UNION JACK WORKING THE TIMER.

“About 1,200 rounds.”

As well as old friends and new, there are a lot of great shooters in Arizona! Silvertip (SASS #52296) was his usual blazing self. So was Half-A-Hand Henri (SASS #9727). Tully Mars (SASS #40161) is pretty much a “How To Shoot Wild Bunch” video every time he comes to the line. I got to meet the amazing King Snake (SASS #86830),

Whirlwind Wendy (SASS #79889) made the drive from California, J.T. Wild (SASS #20339) rolled in from Utah, and Union Jack (SASS #84055) zipped down from Colorado to put on an impressive shooting display.

The camaraderie that makes Cowboy Action Shooting™ such a hoot is ever-present in Wild Bunch and was on display throughout the weekend.

Shotguns broke, replacements were leant. Rifles screwed up, unloading table repairs with plenty of expertise were on hand. Need a magazine? Take one of mine. I’m afraid my shooting companion got a bit spoilt by the Wilson, Les Baer and Ed Brown 1911s that were offered to her when she experienced a jam.

Everyone to whom I spoke had a



ZONA IS THE VERY PICTURE OF CONCENTRATION.



BARBWIRE STRIDING WITH PURPOSE. CHECK OUT HOW MANY MAGS SHE’S CARRYING!



CHAMP (SASS #76470) READY TO ROCK THE STAGE!

great time shooting the match. I've been away from shooting for several years and I must say, this event made me glad I came back. Obviously, I wasn't alone. There were shooters from at least four states who made the trip; they must know a good thing when they see it!

Side note — I had a new shooter along, Ms. Penny Ante, who shot her first WB match. It's a steep learning curve, and it was a challenging match, but the other competitors helped her every inch of the way. As a new shooter, her kit was not yet complete, so in the course of the match, various folks loaned her holsters, belts, mag pouches, ammunition, rifles, pistols, shotguns, and magazines. In the end, it all worked out and she hasn't stopped smiling since she got back to California.

For those of you thinking of making the trip, the drive from SoCal to Phoenix is an easy one, made even more so during the early days of the pandemic. Folks staying home means less traffic on the highway, no lines at the gas stations (and far less Volkswagens, important when one's traveling companion insists on playing "Punch Buggy"). In short, the Arizona State Wild Bunch match was a hoot, one I highly recommend, and I'll be going back!

Well done, Zona and Barbwire, well done, Cowtown Shooters, and congrats to all the winners!

UNION JACK — Men's Modern

FREDRICK JACKSON TURNER — Men's Senior Modern

LADY JANE, SASS #72857— Ladies Traditional

WHIRLWIND WENDY — Ladies Modern

TJ SHARPS, SASS #102709— Senior Traditional

PLEASANT VALLEY KID, SASS #3206
— AZ State Men's Modern Champion

THE BUTCHER, SASS #6630
— AZ State Men's Senior Modern Champion

ZONA — AZ State Men's Senior Traditional Champion

BARBWIRE — AZ State Ladies Traditional Champion

CLAUDIA FEATHER, SASS #2816
— AZ State Ladies Senior Modern Champion

SHOTGUN SHANNON, SASS #94978
— AZ State Ladies Modern Champion

WHERE THE WEST BEGINS!

JAMES COUNTRY MERCANTILE

111 N. Main, Liberty, MO 64068

816-781-9474 FAX 816-781-1470

jamescntry@aol.com www.jamescountry.com

Everything Needed By WESTERNERS!

GUNNIES, TOWNIES, LADIES

CLOTHING, ACCESSORIES, RESEARCH, SUPPLIES



SASS presents . . .



Peace in the Valley

The SASS North Dakota and South Dakota State Championships
June 16 – 19, 2022

Hosted by
The Sheyenne Valley Peacekeepers
Enderlin, North Dakota

- ◇ SASS Membership Required – All SASS Rules Apply
- ◇ 150 Shooter Limit
- ◇ Pre-registration required – No walk-ins
- ◇ Registration deadline – May 20, 2022 - Early bird registration discount before April 29, 2022
- ◇ Main Match entry fee includes snacks, 2 noon meals and Saturday evening Cowboy BBQ
- ◇ Free dry camping – range open for camping at 5:00 pm, Wednesday, June 15, 2022
- ◇ Long range shooting on Thursday and Friday. Distances out to 675 yards.
- ◇ Wild Bunch match Thursday afternoon.
- ◇ Friday Side Matches – Cowboy trap, speed side matches, team shoot & more!
- ◇ Noon meal on Friday – free will donation
- ◇ Friday evening Meet and Greet Social at the saloon
- ◇ 10 Main Stages (7-Saturday, 3-Sunday)
- ◇ Saturday evening Cowboy BBQ, side match awards and entertainment.
- ◇ Vendors and Spectators welcome

For more information contact: email svpcas@gmail.com or
call Wild River Rose at 701-793-4116

For Registration Forms go to: www.sheyennevalleypeacekeepers.com

Join us at the range to shoot in the shade!

SASS & THE ALASKA 49ERS' Cowboy Action Shooting Club

PRESENT THE ANNUAL SASS Alaska State Championship "SHOOTOUT UNDER THE MIDNIGHT SUN"

**12 Stages - July 2-3, 2022
Side Matches July 1**

**At the Matanuska Valley Sportsmen's Shooting Range
Mile 38.5 Glenn Highway, Palmer, Alaska**

Shooter Application and Information:
<https://www.alaskacowboyshooting.com/match-registration-forms>

Match Director: Flaco Joe
scottcrockett1@gmail.com or (907) 982-5097





FJT GIVES THIS MATCH A THUMBS UP!

WILD BUNCH MATTERS CALIFORNIA STATE WILD BUNCH CHAMPIONSHIP 2021

BY FREDERICK JACKSON TURNER,
SASS #28271

A common saying, "Wild Bunch Matters," is often seen as a pin worn on the shooting gear of those who enjoy that demanding but enjoyable adjunct to Cowboy Action Shooting™. Like CAS, those who play the game get to use period firearms which, like the Cowboy counterpart, includes a lever rifle and pump shotgun from the era. But the game differs from Cowboy, as the cut-off is 1912. This allows the competitors to sling J.M. Browning's greatest creation, the 1911 pistol. It's a hoot, a challenge, and great fun.

And I have never seen a better example of how enjoyable it can be

than the 2021 California State Wild Bunch Championship. Once again, the state championship was held at Diamond Dick's Cowboy Town just down the road from that teeming metropolis, Sloughhouse, CA. (Go ahead; pronounce that one. I've lived in California for much of my life and was never certain how to do so properly until this weekend. Trust me; the locals will square you away, pretty quickly!)

Ms. Penny Ante and I pulled in to DD's Cowboy Town after a genuinely scenic tour of rolling farmland in California's picturesque central valley. When we arrived the day before the match, signs of life were everywhere. Campers were being set up, gun carts were unlimbered, and the echo of large-bore firearms punctuated the afternoon breeze. Around us, the range was immaculate, and the entire scene was a reminder of what a wonderful state California truly is, once you get outside the Democrat-run cesspools that are its major cities.

My traveling companion and I stretched our legs, shook off some travel dust, then shook the welcoming hand proffered by Tully Mars (SASS #40161). Tully is the ramrod and match director for the Gold Country Wild Bunch club, as well as one of the better WB shooters you'll ever see. Once signed in, with our shooter packets in hand, we took in the scope of our location for the rest of the weekend. The match takes place on a sizeable, but only a small corner, of the Folsom Shooting Range. It is a vast, well-maintained facility, serving every kind of shooting sport you can imagine. Gazing around, it was yet another reminder of how good California could be...

As we walked the stages, we noted how neatly they were laid out, with easy to follow instructions, and pleasantly shootable target sizes and distances. Nice. After our brief reconnoiter, with big smiles of anticipation plastered on our faces, we headed to our hotel.

Friday dawned clear and cool, and





MS. PENNY ANTE — 102 LBS. OF SHOOTER, 103 LBS. OF AMMO!

after a cup of the most truly villainous hotel coffee I've ever choked down, we made our way to the range for some side matches. There was the usual allotment of speed events for pistol, rifle, and shotgun, but Tully & Co. threw in some inventive twists, like a turkey shoot, which involved 10 knockdowns at a goodly distance, with three positions required to see and engage all the targets. Ms. Penny Ante is a newcomer to this Wild Bunch business and indeed, shooting at all, but has taken to it like a duck to water. As I was squinting at the diminutive target size and distance, without an ounce of hesitation, and with my borrowed rifle, she marched to the line, and at the beep, went to work. She promptly went 10 for 10 on those distant little targets — 10 for 10.

With a borrowed rifle. My turn and... harrumph. Those little suckers were out there! My official story, and I'm sticking to it, is that I was feeling merciful and allowed a couple of the turkeys to live. Well, after her performance, I couldn't exactly blame the rifle, could I? Then, just to rub it in, she did it again. Only this time, she did it even faster. "I LIKE this," she chirped, excitedly. With a mutter, I went to the line, and repeated my dismal performance. Stupid rifle.

Some other fun was waiting. Ms. Penny especially liked the card cutting, which involved shooting five playing cards endwise, from about six feet. With two runs, she split three cards each time. Then, it was my turn. Just as I walked to the line, a cloud passed in front of the sun. And a high wind sprang up.

Honest. It was nearly a gale force hurricane. And, the sun was in my eyes. I think there may have even been an earthquake. Plus, I was feeling merciful. Like the turkeys, many a playing card lived, unmolested, to see another day. Sigh, I never was very lucky at cards.

After a fun afternoon of warm-ups we headed back to the hotel so I could listen to my companion chatter on excitedly about how much fun this was.

Saturday dawned, clear and cool. For reasons of our own, we would have to shoot the first full day pretty much devoid of sleep. Buoyed now by a full thermos of the worst coffee in the history of the hospitality industry, we made the pretty drive back to the range, and, all business now, promptly went to work.

It is a tribute to the stage writing of Tully Mars that even in our sleep-addled condition, there were no Ps, simply because there were no P traps. The stages were challenging, as Wild Bunch should be, but they were also straightforward and eminently shootable. You can usually tell when a match is written by an experienced shooter, and Tully is among the best.

Penny kicked off her part of the match with a clean stage. As this included a pair of can poppers, and she was new to the pump action shotgun, plus borrowing one tailored to my monkey-length arms, she was tickled pink by her success.

Safely removed from Friday's dual menaces of turkeys and playing cards, I shot a creditable stage, gulped down another cup of that truly dreadful hotel java, and set about my posse chores. By the second stage, as good posses do, we had settled into a smooth routine. Sunrise Bill tirelessly manned the clock, spotters were selected from those who were extremely capable and diligent, and the vigilant brass pickers were so sharp-eyed they even found a shotgun bead that had come adrift during a stage.

Stage 10 was a special challenge. There was plenty of movement along the line, two dueling trees, and a Texas Star about 20 yards distant to be engaged with the rifle. I think everyone was a bit intimidated by that last, but everyone on our posse bore down on their sights, and just about all of us

cleaned the diabolical thing.

After the main match shooting was done that afternoon, teams were chosen for a log sawing contest. This involved cutting a 4x4 in half, using only our 1911s. I'm delighted to say I was on the winning Team 1! Or, at least I was, until some doofus shouted out, "Let's do the best two outta three!" (Harrumph. I have to learn to keep my mouth shut!) The second time, Team 2 proceeded to cut that lumber like they were armed with Springfield Armory chainsaws. Then, just to prove that they had earned the win, they did it again.

A couple of things I really enjoyed about the match — on stages which featured seven rifle rounds, the 1911 could be used to engage the rifle targets in lieu of using the rifle. Fun stuff and, if I was a more accomplished pistol shot, or the distances had been a bit less... rifle-y, I'd have been tempted to try it. Respect to the shooters who chose to employ that option!

And what shooters they were. With shooters from several western states on hand. Silvertip, Tully Mars, J.T. Wild, Rumwalker, Cordite, and Molly Magoo.



I HAVE NO IDEA WHAT THIS TROPHY IS FOR, BUT I WANT TO WIN IT!

Folks, these gentlemen and ladies can flat shoot! It upped my game, just being around them.

Thoughtful touches abounded at the range. In addition to the excellent and shooter-friendly permanent stage props, there were snacks on the stages, plenty of bottled water, and even an extremely convenient sink for washing, on each bay. Nice, and like the stages, very thoughtful!

Sunday dawned clear, another beautiful day. California was putting on a show for the shooters. With a will, we went back at it. By now the posse mem-

bers were like old friends, cheering clean stages with a hearty "Whoa-YEAH!" and good-naturedly ribbing the occasionally brain addled. It was good fun and I walked to the last stage with a touch of sadness, not wanting this marvelous match to end. We had laughed, cheered, made new friends, shot dueling trees, playing cards, bell towers, and soda cans, shared stories, mended equipment, and generally had as much fun as it's legal to have.

After a really nice awards ceremony, commendable for its brevity, we were reminded about the best part of this game, kicking back, spending time, sharing stories and a libation or two with old friends and new. Too soon, it was time to saddle up and head for home. Tully Mars and the entire crew at Diamond Dick's Cowboy Town are to be congratulated on a terrific match, and be assured we'll be back for another.

Overall match winners were J.T. Wild (SASS #20399) and Molly Magoo (SASS #74540). Visit <https://cagun-slingers.com/Scores/2021/2021CAWB-Scores.pdf> for complete scores.

LIGHTWEIGHT FOLDING SHOOTING CARTS

RUGGED GEAR

Our carts are as handy as a pocket on a shirt - and dang near as unique as you! With so many options to choose from, you can create a cart that's fittin' to you and your gear. Take a gander at our website to see the different styles, colors, and options!

- Unmatched maneuverability
- Choose from several styles
- Locking front swivel wheel
- Sturdy lightweight frame
- Tons of storage room
- Dual parking brakes
- Folds compactly
- Flat-free tires

BUY NOW & SAVE! USE CODE: **COWBOY** FOR A SPECIAL DISCOUNT!

WWW.RUGGEDGEAR.COM
800-784-4331

ROUGH SERIES

Everybody's a Rough & Tough Cowboy with a Bond Arms ROUGH SERIES handgun!

ROUGH NECK
9mm 2.5 inch barrel **\$269**

ROWDY
45LC/.410 3 inch barrel **\$299**

GRIZZLY
45LC/.410 3 inch barrel **\$377** HOLSTER INCLUDED!

Made In Texas by Texans.

BOND ARMS INC.
817-573-4445 • BondArms.com

BLACK JACK! MISSOURI STATE WILD BUNCH CHAMPIONSHIP

BY JODI COYOTE, SASS #105395,
OKLAHOMA ROUGH RIDER

Friday, September 17, 2021 began with a Doughboy/Teddy Roosevelt mini match, using a Springfield 1903 bolt action for Doughboy or Winchester 1886 lever action for Teddy Roosevelt (or equivalent original caliber rifle issued to its military forces through the end of WWII), along with a 1911 pistol and pump action Model 12 or '97. A group of eight men battled it out over three stages. At Fort Grierson, shooter starts at left window with one hand on each side of the frame. At the beep, snatching and charging their pistol, shooter aims at the five vigilante-shaped targets, double tapping the first, single tapping the center three, and double tapping the fifth target, and repeat. Moving to the center window, shooting the same sequence, while aiming at the cannon silhouettes. Reaching the rifle, shooting the far stars in a two, three, two sweep, then a quick jaunt to the shotgun to engage four knock-down Sandinistas. Doughboy winner goes to Sarsaparilla (SASS #107188) and Teddy Roosevelt winner goes to Artemus Von Schutze (SASS #106783).

As the dew still covered the green grassy thoroughfare, the Flag was raised and began to wave in the wind. The Bear Creek Volunteers played the Star-Spangled Banner and the explosive sound of a cannon signified the start of the 2021 Missouri State Wild Bunch Championship. The Volunteers lead a force of thirty in pursuit of victory.

While playing the Black Jack tables



DOUGHBOY WINNER SARSAPARILLA WITH FOUR-YEAR-OLD FUTURE GUNFIGHTER SIERRA LILY.

at the Stagecoach Saloon the colorful Red, White and Black spinning roulette wheel catches your eye. At first you walk past it to place your rifle on the center table, pointed down range preparing to take down the carefully constructed targets of a lock-box, three Outlaws, and another large lock-box in a one, two, two, two, one sweep. Staging your shotgun on the far table with forethought of creating a diversion by engaging the six bottle knockdowns. Turning to walk back to the first table, your eyes go to the roulette wheel, and you begin to think about what number you want it to land on. As your hand reaches up to spin the wheel, one last nod to sky, and around it goes. Whatever number it lands on is the corresponding knock-down stoneware flagon at which you start your first pistol sweep. Stepping over to the middle table,

reload your pistol and place seven rounds on each of the three static casks, then moving to your rifle and finishing with your shotgun.

Saturday evening ended with Dinner with Friends at the locally owned and operated Missouri Ridge Distillery, featuring a spread of chicken and ribs will all the side fixings. Four-year-old future gunfighter, Sierra Lily (SASS #111012), ran around excitedly with plaques helping her Daddy and Uncle hand out side match awards after dinner.

A round of applause to the State category winners: Ladies Modern — Clear Creek Kiki (SASS #108081); Senior Ladies Modern — Trudy Mae (SASS #76235); Men's Traditional — Artemus Von Schutze; Senior Men's Traditional — Marshal Eli Taylor (SASS #86456); Men's Modern — Buck Clangmore



SATURDAY'S BEST DRESSED



SUNDAY'S BEST DRESSED



MEN'S TRADITIONAL WINNERS





MEN'S MODERN WINNERS



LADIES' MODERN WINNERS



SENIOR MEN'S TRADITIONAL WINNERS



SENIOR LADIES' MODERN WINNERS



SENIOR MEN'S MODERN WINNERS

(SASS #109024); and Senior Men's Modern — Bootheel Bushwhacker (SASS #31903). Also the Overall Winners Jodi Coyote and Buck Clangmor; Congratulations to you all!

Alice K. Grierson (SASS #76680) hosts the costume contest every year. Everyone has two opportunities to win, Saturday night at Dinner with Friends and Sunday on the range. Saturday's Dinner with Friends winners: Best Dressed Gentleman — Handlebar Scratch (SASS #27074); Best Dressed Lady — Ann Sniff; Best Dressed Volunteer Jayhawker John (SASS #106107); and Best Dressed Seniorita Jodi Coyote. Sunday on the range winners: Best Dressed Vigilante — CN Double (SASS

#106936); Best Dressed Volunteer — Trudy Mae (SASS #76235); Best Dressed Military — Big John Elder (SASS #101698); and Best Dressed Seniorita — Clear Creek Kiki.

Thank you to Liberty Range, the Bear Creek Volunteers, and Match Directors Handlebar Scratch and Col. Grierson (SASS #76679) for their time and creativity in hosting the Missouri State Wild Bunch Championship. A special thank you goes out to Newt Pinkerton (SASS #109370) and Buck Clangmor for the delicious smoked half chicken, made right on the range, for the Sunday awards ceremony.

Congratulations to the Bear Creek Volunteers for receiving the 2022 SW Territorial Wild Bunch Championship match, September 9-11, 2022.

We hope to see you all next year in Missouri. Happy Trails!

SASS AFFILIATED MERCHANTS

NATIONWIDE

AWARD REAL ESTATE LLC.

Nation-wide Relocation/ Real Estate Co.

ALABAMA

DENHAM'S

Hats, Custom Leather, Accessories

ARIZONA

PONCHO VEGAS GUNS & COWBOY LEATHER

SA Firearms, Cowboy Leather, Cowboy Clothing and Ammunition, Gun Cleaning & Care Products

TED'S SHOOTING RANGE

SA Firearms, Cowboy Ammunition, Gun Cleaning and Care Products, Indoor Range, and Training

WILD WEST MERCANTILE

Cowboy Clothing, Accessories

CALIFORNIA

AMERICAN GUN WORKS

SA Firearms, Cowboy Ammunition, Gun Cleaning and Care Products

SCULLY

Apparel, Handbags, Leather, Accessories

WILD WEST MERCANTILE

Cowboy Clothing, Accessories

COLORADO

LEVER LOCK

Rifle Accessory

ONLINE OUTPOST

CAS Gun Parts

GEORGIA

ON TARGET SIGHTS

Slip On Brass Sights

IDAHO

NORTH IDAHO LEATHER

Cowboy Leather Products

CATTLE KATE INC.

Cowboy Clothing

INDIANA

TWO BEAR ARMS GUN SHOP

Cowboy Reloading Supplies, Cowboy Ammunition, & Gun Cleaning & Care Products

MINNESOTA

RANGE TACTICAL GEAR

Gun Carts and Targets

MISSOURI

JAMES COUNTRY MERCANTILE

Cowboy Clothing, Gun Cleaning & Care Products, Tin Ware, Hats, Special Order Clothing, Patterns for Clothing

MONTANA

CHOICE AMMUNITION

Cowboy Reloading Supplies, Cowboy Ammunition

NEW MEXICO

HUNTER SUPPLY

Cowboy Reloading Supplies, Cowboy Leather Products, Cowboy Ammunition, & Gun Cleaning & Care Products

NEW YORK

L.P.L. BULLETS

Cowboy Reloading Supplies

OHIO

AMERICA'S GUN STORE, LLC

SA Firearms, Cowboy Leather Products(Triple K) Cowboy Ammo

FASTSIGNS OF DOWNTOWN CINCINNATI

Signs, Banners, Promotional

VANDALIA RANGE & ARMORY, INC.

SA Firearms, Cowboy Ammunition, & Cowboy Reloading Supplies

OKLAHOMA

GREEN COUNTRY AMMUNITION

SA Firearms, Cowboy Ammo, & Cowboy Reloading Supplies

PENNSYLVANIA

ENCK'S GUN BARN & INDOOR RANGE

SA Firearms, Cowboy Ammo, & Cowboy Reloading Supplies

SOUTH CAROLINA

BULLETS BY SCARLETT

SA Firearms, Cowboy Ammo, & Cowboy Reloading Supplies

SOUTH DAKOTA

BLACK HILLS AMMUNITION

Cowboy Ammunition

TENNESSEE

SLATER'S IN HOUSE GUNS

Single Action Firearms, Single Action Gunsmithing, Laser Engraving, Transfers, Non SASS Firearms

TEXAS

CIMARRON FIREARMS

Hand Guns, Custom Guns, Rifles, Shotguns, Gun Leather, Accessories

KIRKPATRICK LEATHER CO.

SA Firearms, Cowboy Leather Products, Gun Cleaning & Care Products

LONG HUNTER'S

SA Firearms, Cowboy Leather Products, Gun Cleaning & Care Products

MERNICKLE HOLSTERS

Custom Leather

TEXAS JACKS

Clothing, Shoes, Accessories, Guns, Knives, Dry Goods

TWO WRIGHT ARMS CO.

SA Firearms, Cowboy Leather Products, Cowboy Reloading Supplies, Cowboy Ammunition

VIRGINIA

TAYLOR'S & COMPANY

Hand Guns, Rifles, Shotguns, Ammunition, Gun Leather, Parts, and Accessories

BECOME A SASS SUPPORTING STORE & WE'LL REFER OUR MEMBERS TO YOU!

IT'S SIMPLE. BECOME A SASS SUPPORTING STORE AND WE'LL REFER OUR MEMBERS DIRECTLY TO YOU.

THAT'S RIGHT. WITH OUR FAST GROWING POPULATION OF COWBOY ACTION SHOOTING™ MEMBERS, SASS WOULD LIKE TO SUPPORT YOU BY REFERRING OUR MEMBERS TO YOU. WHY? BECAUSE WE NEED SASS AND COWBOY ACTION SHOOTING™ KNOWLEDGEABLE GUN STORES, NATIONWIDE, TO REFER OUR MEMBERS.

How Does it Work?

SASS SUPPLIES YOU, WITH:

- * SASS MEMBERSHIP APPLICATIONS
- * INFORMATIONAL BROCHURES
- * A LISTING ON OUR WEBSITE WITH A LINK TO YOUR WEBSITE

+ A LISTING IN THE COWBOY CHRONICLE MONTHLY DIGITAL EDITION WITH A LINK TO YOUR WEBSITE

+ A LISTING IN THE COWBOY CHRONICLE ACCESS TO POST PROMOTIONAL SALES ON THE POPULAR SASS WIRE FORUM MERCHANTS CORNER

+ A SASS AFFILIATED MERCHANT STICKER WITH YEAR TO PLACE PROUDLY IN YOUR STORE

+ A CERTIFICATE THAT SHOWS YOU ARE A SUPPORTING DEALER IN GOOD STANDING

+ WE REFER OUR MEMBERS TO YOU FOR RELATED GOODS & SERVICES

+ YOUR LOGO AND BUSINESS INFO WILL BE ADDED TO A FLYER WHICH WILL BE INCLUDED IN EACH NEW MEMBER PACKAGE. (PLEASE SEND HI-RES LOGO TO AMBER@SASSNET.COM)

+ AFFILIATED MERCHANTS WILL BE FEATURED IN EMAIL BLASTS TO ALL ACTIVE MEMBERS WITH AN EMAIL ADDRESS. ON A QUARTERLY BASIS.

WHAT DO YOU HAVE TO DO TO BE A SASS SUPPORTING STORE?

- + EDUCATE YOURSELF TO HOW SASS FUNCTIONS BY READING YOUR SASS INFORMATION PACKET

+ DISPLAY OUR MEMBERSHIP APPLICATION IN THE SUPPLIED COUNTER TOP DISPLAY CONTAINER

+ DISPLAY YOUR SASS SUPPORTING STICKER WHERE REFERRALS CAN SEE IT

+ BE HELPFUL, FRIENDLY AND ATTENTIVE WHEN A CUSTOMER MENTIONS SASS

+ YOU MUST BE A SASS MEMBER

How Do I Qualify?

IF YOU ARE A RETAIL STORE THAT SELLS SINGLE ACTION FIREARMS, AMMO, COWBOY CLOTHING OR OTHER COWBOY PRODUCTS AND YOU ARE A SASS MEMBER, YOU QUALIFY! IT'S THAT SIMPLE!

How Do I Sign Up?

VISIT THE SASS AFFILIATED MERCHANTS PAGE AT [HTTP://WWW.SASSNET.COM/AFFILIATED-MERCHANTS-APP-001A.PHP](http://www.sassnet.com/affiliated-merchants-app-001a.php) TO DOWNLOAD AN APPLICATION.

FOR MORE INFORMATION CONTACT RUBY RUTHLESS AT THE SASS OFFICE AT (505) 843-1320, OR EMAIL RUBY RUTHLESS DIRECTLY AT RUBY@SASSNET.COM

HILL COUNTRY CHARM TEXAS STATE WILD BUNCH CHAMPIONSHIP 2021 ~ HOSTED BY THE TEXICAN RANGERS

BY DUSTY BODDAMS, SASS #1907

PHOTOS BY DUTCH VAN HORN, SASS #51153

The Texas State Wild Bunch Championship traveled down to the beautiful Texas hill country for 2021 to the neat old German town named Fredericksburg which is located just outside of Luckenbach, Texas whose slogan is "Everybody's Somebody in Luckenbach." The host club for 2021 was the Texican Rangers, who have a great range located on an original real working ranch, and they made sure, through most generous hospitality and hard work, to live up to Luckenbach's slogan. Our hats are off to the match directors Asup Sleeve (SASS #90965) and Burly Bill Brocius (SASS #102476), along with the great crew that made everything look seamless and effortless. Opening ceremony Friday mid-morning kicked off the Wild Bunch side matches including Bamm combat, Bamm long range, Gamm, Doughboy, fastest 1911, man on man, and a signature side match called Blazing Saddles where the default was setting on top of an elevated saddled barrel on coasters with a steel track. At the beep shooter engaged the seven rifle targets then hit a lever making the "horse" go traveling down the track. As this was happening, the shooter used a 1911 to shoot two targets on the left (one of them three times the other four), quickly recharged the pistol and repeated the sequence on the right for a total of 14 rounds. It



OVERALL WINNERS DUSTY BODDAMS AND MISS TREATED

all happens rather quickly and is most exciting. They also had a team match by way of random draw with four shooters on each team representing each of the characters from the original *Wild Bunch* movie. Each team member shot individually at a different scenario with a different combination of weaponry. Fun times. Main match featured 10 unique and original stages that were designed to challenge the competitors through movement, sweeps, and distance. This very well ran match also had lots of pistol shooting which is the star of Wild Bunch along with some good solid shotgun and rifle components. Saturday after the main match it was heard that an impromptu pistol match broke out at the 125-yard Bamm targets and the shooters were successful in hitting these targets with the .45 automatics offhand. Evidently they were never told it's a close quarter weapon! Saturday night the Texicans furnished the meal and bought everyone chicken fried steaks with all the trimmings. Sunday continued with the balance of five stages. A dynamic awards ceremony by Burly Bill and Asup presented really high quality belt buckles to the new Texas State Champions. A nice furnished taco lunch and a nice prize table with primers and powder ended this great match of the Texican Rangers. I'm Dusty Boddams and that's the Boddam line.

Thousands of Items
for the Cowboy and Black Powder
Cartridge Shooter

HOLSTERS & BELTS
GUNS
COWBOY CLOTHING
BLACK POWDER
LOADED AMMO

Buffalo
ARMS CO.

8am - 4:30pm M - F PST
660 Vermeer Court, Ponderay, ID 83852 **208 263-6953**

WWW.BUFFALOARMS.COM



ASUP SLEEVE



BURLY BILL BROCIUS



COMIC BOOK
CORNER

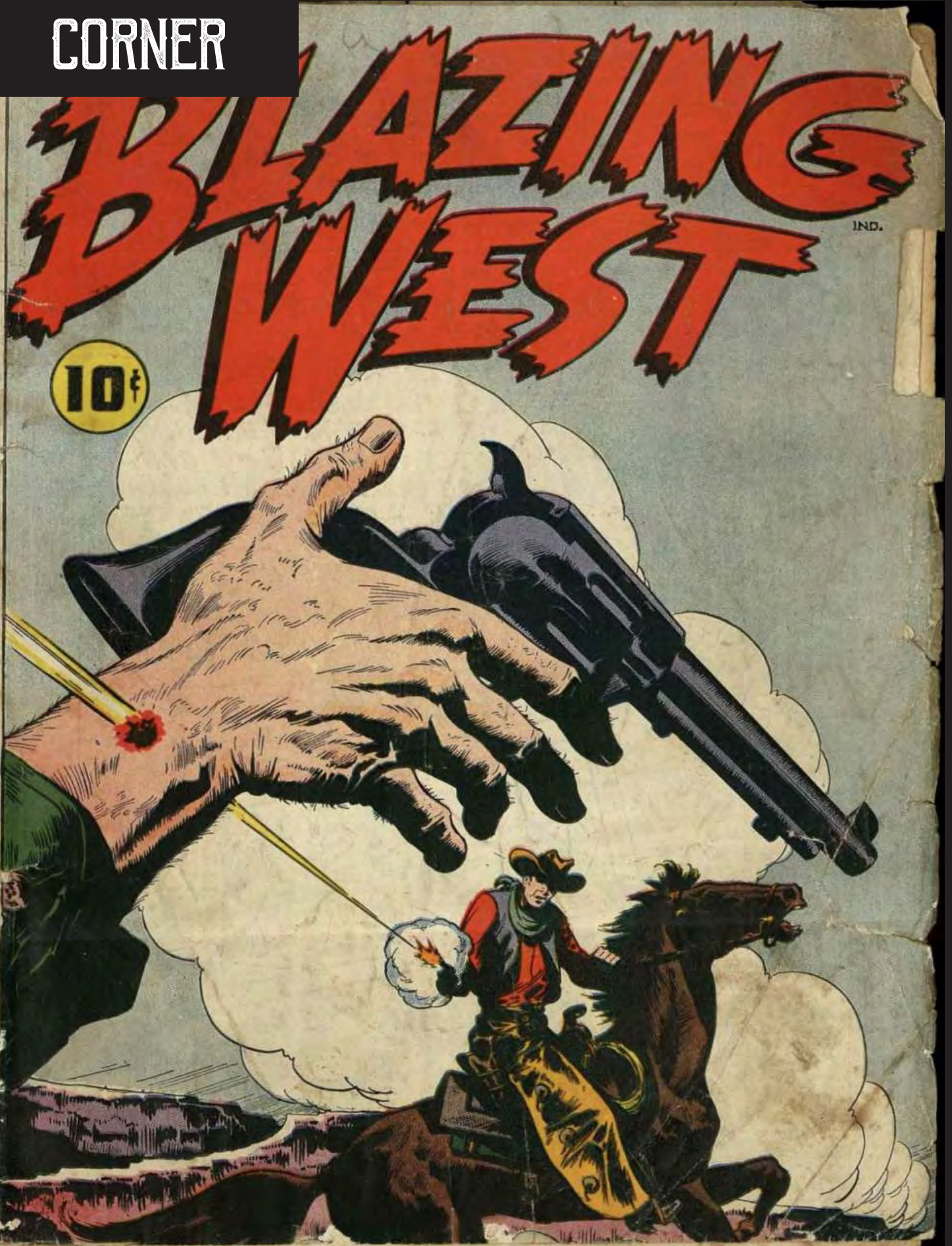

BUFFALO BELLE

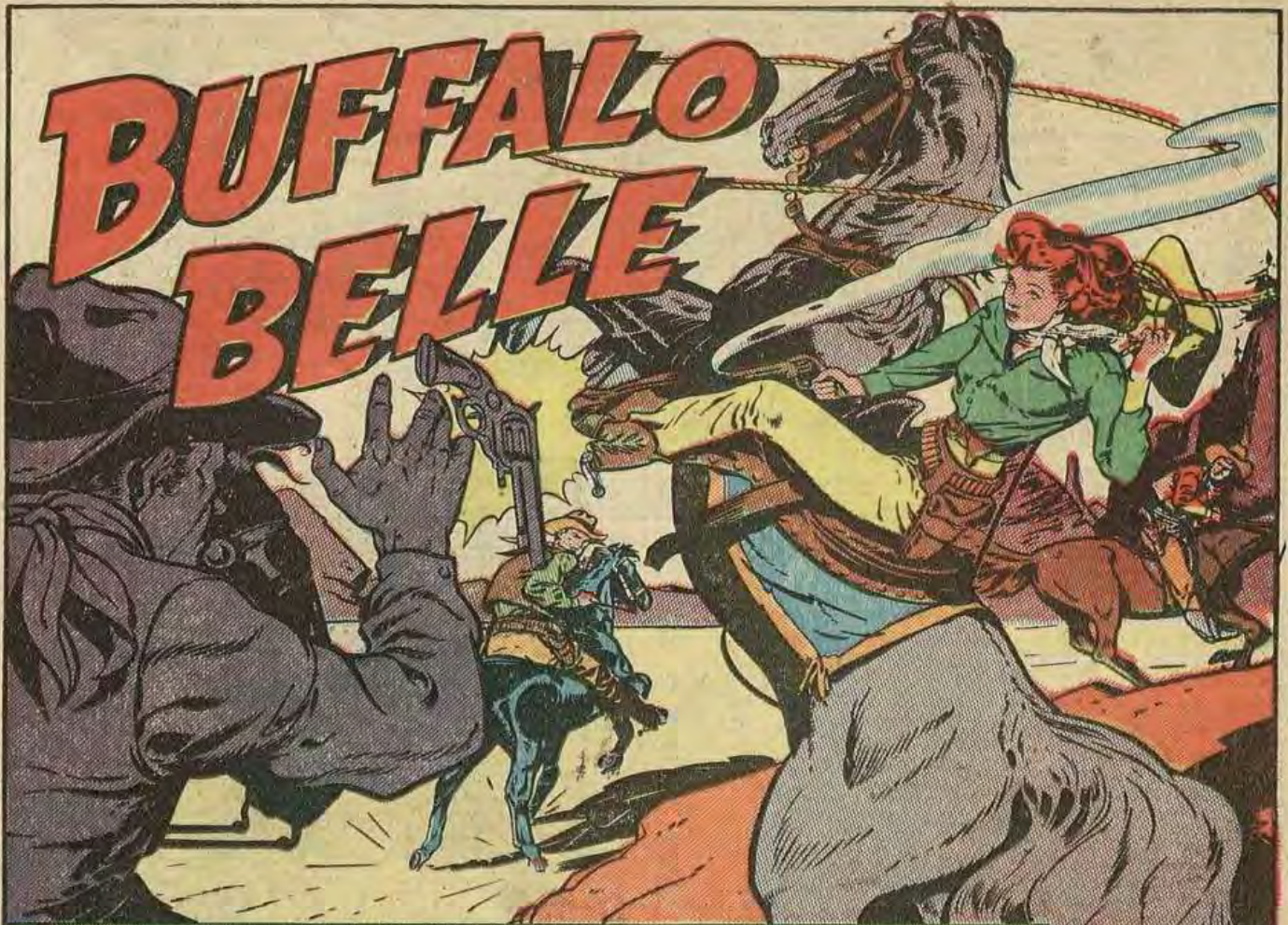

DANGER...SHOTS IN THE NIGHT...THE THUDDING OF HOOVES...THE WILD CHEROKEE STRIP KNEW THEM ALL! IT WAS SCARCELY THE PLACE FOR A GIRL...BUT BUFFALO BELLE WAS NO ORDINARY GIRL! STAND BY FOR A HARD-RIDING, FAST-SHOOTING DAUGHTER OF THE OLD WEST...AND WATCH OUT FOR FIREWORKS!

TERROR GRIPS A SLEEPY LITTLE TOWN!

RED CARVER'S RIDIN' FER TOWN, BOYS! IF YUH WANT TO LIVE... SCATTER!



CARVER'S HEADIN' THIS WAY, MIKE... HE'S SET FER KILLIN'! AM' THE SHERIFF'S SET AN AMBUSH FOR HIM... RIGHT OUTSIDE!

ULP! THAT MURDERIN' DESPERADO... COMIN' HERE?



PUT THEM BOTTLES ON THE FLOOR! HURRY! DON'T SIT THERE LIKE A SQUATTIN' INJUN!

AND GIT MY HEAD BLOWN OFF? NOT ME!





HEY, SHERIFF! THAT GIRL'S JUST STANDIN' THERE! SHE'LL BE A CLAY PIGEON IF CARVER OPENS UP!

WELL, I'LL BE!... HEY, YOU...GET INDOORS! TAKE COVER!

WHY? I'M NOT AFRAID OF ANYTHIN'!



MEET 'BUFFALO BELLE' TRENT... HARD-RIDING PRAIRIE SCOUT AND CRACK MARKSMAN... WITH A MIND OF HER OWN!

YUH HEARD WHAT I SAID, GIRL! TAKE COVER!

SO YUH'RE THE NEW SHERIFF WHO'S TRYIN' TO BRING LAW AND ORDER TO THE STRIP! WELL, IF THERE'S GOING TO BE ANY SHOOTIN'... I'M STAYIN' RIGHT WHERE I AM!



HAVEN'T YUH ANY SENSE AT ALL? CARVER'S A KILLER! HE'D JUST AS SOON SHOOT A WOMAN AS NOT! I TOOK PAINS ARRANGIN' THIS RECEPTION... AN' YUH'RE NOT SPOILIN' IT!

PUT ME DOWN! OHH!



A MOMENT LATER... HERE HE COMES, MISS! YUH'RE LUCKY TO BE WHERE HE CAN'T SEE YUH!

THE MOST DANGEROUS BAD MAN IN THESE PARTS, EH? NOW TO WATCH THAT HIGH-AN'-MIGHTY SHERIFF HANLEY SPRING HIS BIG SURPRISE!

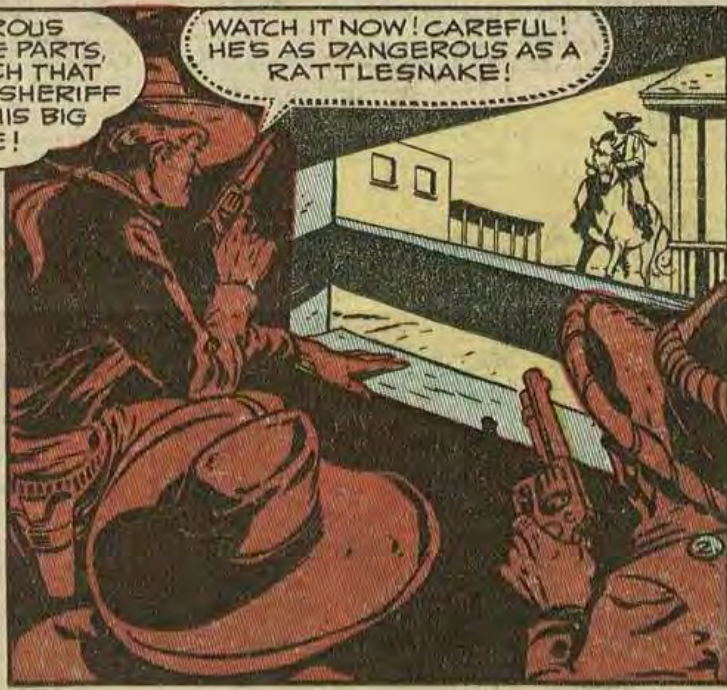

WATCH IT NOW! CAREFUL! HE'S AS DANGEROUS AS A RATTLESNAKE!

IF YUH WANT TO LIVE, RED...REACH! WE'VE GOT YUH COVERED!

HUH?...TRYIN' TO DRYGULCH ME, EH?



THANKS FOR THE WARNIN', HOMBRE!

UGH! MY SHOULDER..

BANG!

BANG!



AS GUNS ROAR FROM THE SHADOWS...

YUH'LL NEVER GIT ME!

BANG! BANG!



L-LOOK OUT!

CLEAR THE WAY, SUCKERS!



AT THIS CRUCIAL MOMENT - BUFFALO BELLE TAKES A HAND!

HE'S FAST ON THE DRAW AND AS VICIOUS AS THEY COME! JUST ONE CHANCE...

HAW-HAW! I CROSSED 'EM UP!

SWISHHH!



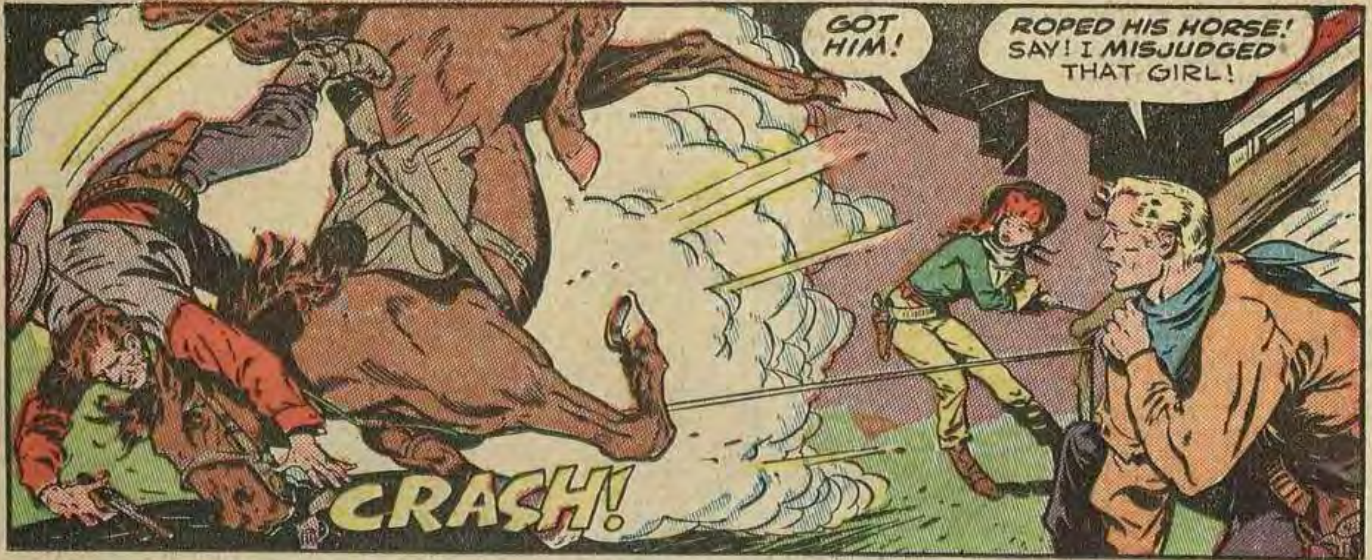

CRASH!

GOT HIM!

ROPED HIS HORSE!
SAY! I MISJUDGED
THAT GIRL!



BUT THEN... I'VE STILL GOT A FIGHTIN' CHANCE TO GIT TO TH' FOOTHILLS!---AH! TAKES A KNIFE TO FREE A HORSE QUICK!



HE CAN RIDE AS FAST AS HE CAN SHOOT! I'M NOT GAININ' ON HIM!

BANG!
BANG!



I'VE LOST HIM! HE MUST KNOW EVERY FOOT OF THIS COUNTRY! I DO TOO, BUT--THOSE SHADOWS...



WHEN BELLE RETURNS TO THE HOTEL...

CARVER GOT AWAY!
IS--IS THE SHERIFF
ALL RIGHT?

HE'LL LIVE,
MISS!



I KNOW SOMETHIN' ABOUT YUH NOW!
BUFFALO BELLE, THEY CALL YUH!
YUH KIN OUTGUESS AN' OUTSHOOT
A DOZEN MEN! SO...

WELL, I... ER...
WHAT'S ON
YORE MIND,
SHERIFF?

CARVER ROBBED A BANK IN JEFFERSON FALLS AN' MADE OFF WITH THE LIFE SAVIN'S OF HALF THE FARMERS IN THE STRIP! THIS IS STILL A CATTLEMEN'S TERRITORY, BELLE! A FEW OF THE CATTLEMEN, LIKE McNALLY, WOULD WANT TO SEE THE FARMERS RUINED! SO THEY'RE STANDIN' BEHIND CARVER AND EGGIN' HIM ON!



CARVER HAS TWO WOUNDED MEN, AN' HE NEEDS SUPPLIES! WHEN I HEARD HE WAS HEADIN' THIS WAY, I TRIED TO AMBUSH HIM! BUT NOW HE'LL TAKE TO THE HILLS AN' COUNT ON GETTIN' HELP FROM McNALLY! THE CATTLEMEN WON'T WANT TO SEE HIM CAPTURED!



YUH KNOW THIS TERRITORY AS WELL AS I DO, BUFFALO BELLE! EVERY FOOT OF IT! CARVER'S GOT TO BE CAUGHT BEFORE HE LEAVES THE STRIP WITH THAT MONEY! I CAN'T GO AFTER HIM MYSELF, SO I'M MAKIN' YUH MY DEPUTY!

M-ME? YOUR ... DEPUTY?

HOWLIN' COYOTES!



STARTLING NEWS SPREADS QUICKLY!

A FEMALE DEPPITY! DOGGONE--SHERIFF HANLEY MUST BE RUNNIN' A FEVER!

NOT WHEN HE'S CHOSEN BUFFALO BELLE TRENT! SHE'S A PRETTY GAL--BUT A BATTLIN' MAVERICK!



WITH DAWN, BUFFALO BELLE LEADS A TEN-MAN POSSE INTO THE FOOTHILLS!

A FEW WADDIES PASSED THIS WAY, RIDIN' HARD--CARVER AN' HIS BOYS, I'LL BET! LOOK--THE FOLIAGE IS BROKEN OFF SHARPLY AT THE EDGE OF THE ROAD!

YUH GOT AN EYE LIKE AN EAGLE, BELLE--AN' YUH TRACK LIKE AN INJUN!



CAKED BLOOD! NO DOUBT OF IT! LUKE HANLEY SAID TWO OF CARVER'S MEN WERE WOUNDED! IF THEY EASED A WOUNDED MAN AGAINST THAT BOULDER, TO REST HIM AFTER A HARD RIDE--

YEAH! MEBBE THE TRAIL ENDS HERE!



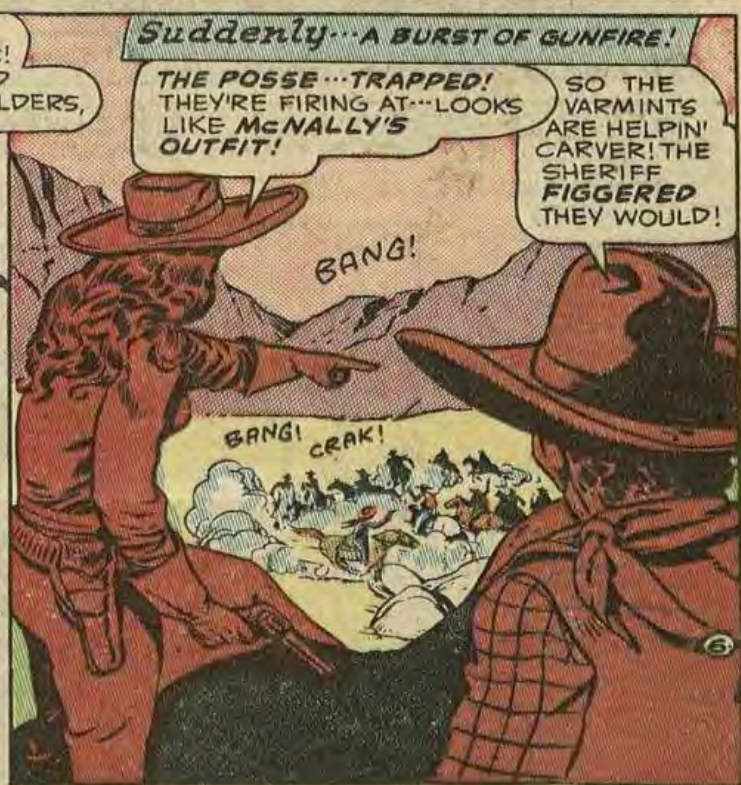

THE POSSE'S OUTNUMBERED!
THEY'LL BE WIPED OUT! WE'VE
GOT TO SAVE THEM!



BUT HOW,
BELLE? EVEN IF WE
COULD GIT TO THEM
IN TIME... THERE'S
ONLY THE
THREE OF
US!

YUH'VE SEEN THAT RELIC BEFORE,
I GUESS... IT'S A LANDMARK! A
PRAIRIE SCHOONER! IT'S BEEN
ROTTING THERE FOR THIRTY
YEARS!

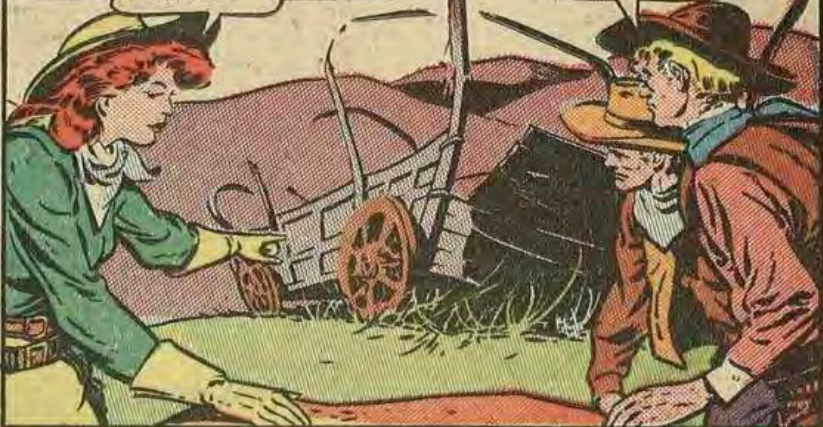

SURE I SEEN IT...
DOZENS OF TIMES!
BUT WHAT'S IT
GOOD FER?

WE'LL GET IT MOVIN'! IF WE
PUSH IT TO THE EDGE OF THAT
SLOPE... IT'LL GO CRASHIN'
DOWN INTO THE GULCH
UNDER ITS OWN MOMENTUM!
AND WE'LL BE ON IT!



EASIER
SAID THAN
DONE!...
UGH! THEM
WHEELS SURE
ARE DEEP-
RUTTED!

CLIMB ABOARD!
SHE'S STARTIN'
TO ROLL!



ROLLING... CRASHING... THE OLD WAGON DESCENDS
THE SLOPE LIKE A TWENTY-TON JUGGERNAUT!



IT'S WORKIN'! WE'RE
HEADIN' RIGHT FOR
MCNALLY'S MEN!

BANG!

BANG!

BANG!



YUH CRINGIN' COYOTES!
I'LL GIT THAT GIRL IF
IT'S THE LAST...



GRIM MOMENTS LATER...

McNALLY AND CARVER WON'T
BE TROUBLIN' THE STRIP NO
MORE! ABOUT SIX OF THE
BUZZARDS STAYED ALIVE
...BUT WE'VE GOT 'EM ROPED
GOOD AND PROPER!

HURRAH
FER BUFFALO
BELLE!



Next day...

I THINK I'D BETTER
RETURN THIS BADGE,
LUKE!

SHUCKS, BELLE...YUH
CAN'T RETURN IT! THE
BOYS WOULDN'T STAND
FOR THAT! THE DECENT
CATTLEMEN HAVE MADE
A TRUCE WITH THE
FARMERS! IF YUH WANT
TO HELP THEM KEEP IT
...YUH'VE GOT TO STAY
ON AS MY DEPUTY!

BUFFALO BELLE RETURNS--NEXT ISSUE!

MERCANTILE

877-411-SASS ~ SASSNET.COM



2022 SASS & CAS TRUCKER HAT \$27.95

New for 2022! The Old Favorite Trucker hat by Legacy is made from a washed cotton twill crown, mesh from 65/35 cotton/polyester, and has an unstructured, six-panel, low-profile, pre-curved with a green under visor. Legacy's original Old Favorite trucker hat is the perfect fit using super soft mesh and adjustable snap closure. Where comfort plays a role in the classic trucker hat! Choose from the SASS Marshal logo with a crimson bill, or the CAS logo with a washed blue bill or, get one of each! *Shipping Included in the Price*



CAS 2022 EDITION T-SHIRT \$29.95

Order your SASS Official 2022 Edition T-Shirt. This shirt comes in a soft Tri-Blend material and Dark Grey color. Sizes Small-3X (2X & 3X are \$5 more) MADE IN THE USA! Will ship by January 11th



CAS 2022 EDITION PULLOVER HOODIE \$44.95

Order your SASS Official 2022 Edition Pullover Hoodie. This super soft hoodie comes in Black. Sizes Small-3X (2X & 3X are \$5 more) MADE IN THE USA! Will ship by January 11th

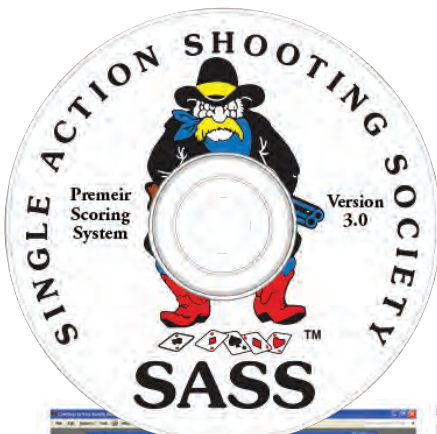

SASS MATCH MANAGEMENT & SCORING SYSTEM \$340.00

(Includes \$15.00 for Shipping)
For SASS Affiliated Clubs Only

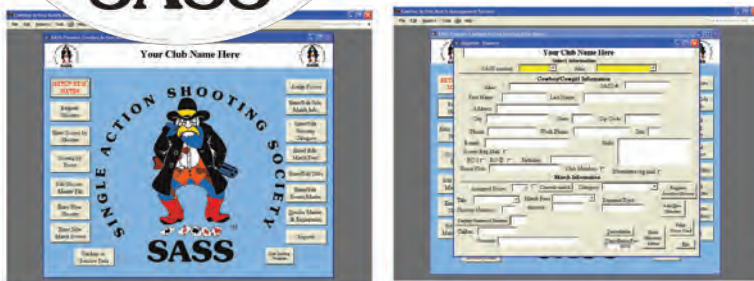

SASS FLAG \$25.00

3'x 5' SASS Flag. Full color logo printed on a white flag. Hem with Header and Grommets. Wave your SASS Flag proudly!

GENERAL STORE

YOU PICKED THE WRONG STAGECOACH
AND OTHER SHORT STORIES FROM THE ARIZONA TERRITORY

RIK DANIELSEN

Written by Rik Danielsen aka Prescott Parson - SASS #104764
Available through Amazon.com & www.Warner.House
MSRP: \$14.99

INDIAN CREEK LEATHER
Custom Leather Mills

Competition Rigs
Buscadero Rigs • Shotgun Belts
Cuffs • CCW Holsters & Belts

"Quality that takes your breath away, not your wallet"
Indiancreekleatherco.com
419-680-9069

COWBOY CHOICE AMMUNITION

MFG. IN MONTANA

SMOKELESS CENTRAL FIRE METALLIC CRT'G

- 100% Hand-Loaded
- New Brass Always
- Hi-Tek Coated Bullets
- Federal Primers
- Less Recoil/Muzzle Flip
- Most Calibers Available
- Wild Bunch .45 ACP
- Meets SASS Power Factors

844-446-Ammo (2666)
COWBOYCHOICEAMMUNITION.COM

"Wells Fargo" Ammo Bag!

250 Rounds each
100% hand-loaded

- .38 Special
- .357 Magnum
- .41 Remington Mag
- .44 Magnum
- .45 Colt
- .45 Schofield

844-446-Ammo (2666)
COWBOYCHOICEAMMUNITION.COM

MAKE YOUR OWN HOLSTERS!
FIND SLICKBALD PATTERN PACKS & KITS AT:

- SPRINGFIELDLEATHER.COM
- WEAVERLEATHERSUPPLY.COM
- MAKERSLEATHERSUPPLY.COM
- LEATHERCRAFTERSJOURNAL.COM

AGI American Gunsmithing Institute
INTRODUCTION TO HOLSTER MAKING WITH SLICKBALD - 4 DVDs - 7+ HOURS!
AmericanGunsmith.com @SLICKBALD
Item #LHMC3504

OR HAVE YOUR DREAM HOLSTER MADE!
SLICKBALD@SLICKBALD.COM

BANG AND CLANG

Got Bullets?

LUBED AND COATED BULLETS
NOW OFFERING MATCH AMMO!

BangAndClangLLC.com
support@BangAndClangLLC.com

GEORGE F MARTIN
PO Box 400
MIMBRES, NM 88049
860-395-3643

WWW.CATTLEKATE.COM

Classic Old West Clothing
Handmade in USA
1-800-332-5283 (KATE)

BARLEYCORN OUTFITTERS
Buy, Sell & Trade Firearms
Specializing in Cowboy Action & Modern Firearms

Export, PA Matt Mastorovich, Owner, FFL
BarleycornOutfitters@gmail.com
724-468-6093 (Office) / 724-757-2834 (Cell)
BarleycornOutfitters.com

Outlaw Gambler, Proprietor

Classic Old West Arms
Specializing in Original Winchester and IAC 1897's. The new IAC COWBOY 87's are in stock and ready for shipment. All have the updates and modifications.
Visit us at: classcoldwestarms.com

We produce and sell best capper for Remington New Army and other guns!

Please visit our shop: www.polishcappers.com

We sold many cappers in 2017 world-wide and we have many happy customers in USA.

The capper holds over 150 caps of all types and sizes.

The price is c.a. \$49.00 including delivery. We are shipping world-wide.

THE FRENCH VAQUERO
The Story of a Cajun Gunfighters Journey

JOHN "BLUE" BUNCH

Amazon books.com Barnes noble.com

TO ADVERTISE IN THE GENERAL STORE PLEASE CONTACT:
Square Deal Jim | 410-531-5456 | chronicleads@sassnet.com

TO ADVERTISE IN THE GENERAL STORE PLEASE CONTACT:
Square Deal Jim | 410-531-5456 | chronicleads@sassnet.com

GENERAL STORE

JBS & Co

Old West Pine Caskets and Cremation Urns

We also do Custom Crosses and Pet Caskets, small, medium, and large.



"It would be my Honor to furnish you with any of our products."
-Badlands Burt

(325) 668-5132 • <https://jbs-co.business.site/> • 1161 CR 461, Roscoe, TX 79545

Online Outpost

"One stop shopping"

Upgraded Cowboy
Action Shooting Gun
Parts & Accessories

970-259-7795
onlineoutpost.net

TERRI LITTLE AKA
DURANGO TRADER
SASS 98667

**EXCITING NEW TALES
OF OLD WEST ACTION**

**AVAILABLE
FROM AMAZON.COM
GPHUTCHINSON.COM**

GUNSMOKE 65th
An American Institution SEMI-CENTENARY

Celebrating 50 Years
of Television's Best Western
By Ben Costello

Starting on September 10, 1955, and continuing for more than 600 episodes over the next twenty years, Gunsmoke ruled the airwaves. Never in the history of television had a show so captured the hearts of both youngsters and adults. Each week, Marshal Matt Dillon and his friends would

face a new threat to the peace and lawfulness of their frontier home of Dodge City, Kansas—and each week, goodness and determination prevailed. It was the perfect antidote for a country still emerging from the darkness of World War II.

**It's the 65th Anniversary
of America's beloved
western! We have a
limited number of
author-signed copies
available!**

GUNSMOKEBOOK.COM

~ ADVERTISING INDEX ~

WILD WEST MERCANTILE	IFC
CHORRO VALLEY REGULATORS.....	2
TEXAS JACK WILD WEST OUTFITTER.....	5
GOLDEN GATE WESTERN WEAR.....	6
UNIQUE TEK	6
HENRY REPEATING ARMS.....	9
CIMARRON	13
OREGON TRAIL BULLETS COMPANY	18
DIXIE DESPERADOS	21
COMPETITION ELECTRONICS	27
MADE TARGETS.....	28
WESTERN MUSIC ASSOCIATION	29
HARVARD GHOST RIDERS.	31
USPSA.....	31
MERNICKLE HOLSTERS.....	32
EVIL ROY'S SHOOTING SCHOOL.....	34
RIM ROCK BULLETS	37
DIXIE GUN WORKS, INC.....	41
WEAVER LEATHER SUPPLY	41
JAMES COUNTRY MERCANTILE	45
SHEYENNE VALLEY PEACEKEEPERS.....	45
ALASKA 49ERS	45
RUGGED GEAR	49
BOND ARMS	49
SASS AFFILIATED MERCHANTS.....	53
BUFFALO ARMS COMPANY	54
SASS MERCANTILE.....	65
SASS GENERAL STORE	66-67

SASS AFFILIATED CLUBS 2022 MONTHLY SHOOTING SCHEDULES

CLUB NAME	CITY	MATCH DAY	PHONE	CONTACT	RANGE LOCATION
AUSTRALIA					
Westgate Marauders	Port Melbourne	2nd Saturday	61 0433419284	Stampede Pete	Melbourne International Shooting Club
Shooters Union Australia Ltd	Various Ranges	As Sched.	+61 409 471 423	Painted Mohawk	Various Ranges Across Australia
AUSTRALIAN CAPITOL TERRITORY					
Majura Rangers	Majura	3rd Sun	N/A	Blinky	SSAA-ACT Shooting Range
QUEENSLAND					
Dalby Pioneers	Dalby	4th Sun	+0458 510 122	Mrs. H	N/A
Sporting Shooters' Association of Australia, Inc.	N/A	As Sched	+61 447 831 154	R. C. Shot	NSW, QLD, VIC, ACT, SA, WA, NT, TAS
Wallumbilla Regulators	Wallumbilla, QLD	As Sched.	61+ 428 464 606	Slippery Shayne	Wallumbilla Rifle Club
VICTORIA					
Little River Raiders	Little River	3rd Sun	61 407 553 281	Sambucca Kid	Eagle Park Shooting Complex
AUSTRIA					
City Marshals	Graz	As Sched.	+43 699 131 154 83	Clint Coldwell	Shooting Range LH Graz
Sweetwater Gunslingers Austria	Vienna	Sat. As Sch	+43 (0) 664 49 80 32	Fra Diabolo	Club Wiener Pistolenschutzen
CANADA					
Nova Scotia Cowboy Action Shooting Club	Camden	As Sched.	902-890-2310	Wounded Belly	Nova Scotia Muzzle Loading Association
ALBERTA					
Canadian Historical Arms Society	Leduc County	Every Wed.	780-977-5977	Alberta Jayhawk	Genesse Ranger
Porcupine Hills Shadow Riders	Granum	2nd & 4th Saturday	403-687-2284	Southwest Trapper	Willow Lane Ranch
BRITISH COLUMBIA					
Heffley Creek Gun Club	Heffley Creek	As Sched.	250-573-2885	Gunfighter Jim	N/A
Kamloops Cowtown Cowboys	Kamloops	As Sched.	250-573-2885	Gunfighter Jim	Kamloops Target Sports Association
Red Mountain Renegades	Mission	1st Sun	778-241-5538	Goldie Stone	Mission and District Rod and Gun Club
Valley Regulators	Courtenay	3rd & 5th Sat	250-897-2194	Little Edgy	Courtney Fish and Game Protective Association
Victoria Frontier Shootists	Victoria	2nd Sun	250-744-4705	Black Ashley	Victoria Fish & Game Protective Association
NEW BRUNSWICK					
Beaubassin Range Riders	Saint-Andre LeBlanc	2nd Sat & 5th Sat	506-312-3330	Frenchy Cannuck	Cap Pelee Gun Club
ONTARIO					
Ontario Single Action Federation	Guelph, ON	As Sched.	519-362-1184	Doc Lonesome	N/A
Prairie Dog Rebels	London	As Sched.	519-860-2004	Currahee Kid	Crumlin Sportsmen's Association
Ruff's Regulators	Cornwall	As Sched.	514-409-6117	Marshall MacPhee	Cornwall Handgun Club
Square Circle Wranglers	Clarence-Rockland	As Sched	613-797-4855	Red Storm	Eastern Ontario Shooting Club
QUEBEC					
Centre De Tir Granby Multi-Sports	N/A	As Sched.	N/A	N/A	N/A
Club De Tir Beausejour	Levis, Quebec	As Sched	418-609-2139	Lieutenant Bluberry	Chasseurs et pecheurs Levisiens inc.
SASKATCHEWAN					
Saskatchewan Association of Wild West Shooters	Saskatoon	As Sch	306-222-2480	Dusty Dawn	Saskatoon Muzzle Loading Club
CZECH REPUBLIC					
Association of Western Shooters	Pelhrimov	As Sched	42077776066	Colbert	Shooting Range Pelhrimov
FINLAND					
Classic Old Western Society of Finland	Loppi	As Sched.	+358-50-5174659	Captain Woodbury Kane	N/A
SASS Finland	Loppi	As Sched.	+358 50 5174659	Woodbury Kane	Loppis Shooting Range

CLUB NAME	CITY	MATCH DAY	PHONE	CONTACT	RANGE LOCATION
-----------	------	-----------	-------	---------	----------------

FRANCE

Buffalo Valley	Châteauneuf-en-Thymerais	As Sched.	06 08 83 89 36	Slye Buffalo	Avenir Sportif Thymarias
Bull Run Valley	Sainte Opportune	As Sched.	06-47-52-09-37	Ben Calhoun	Association Sportive Flers Messei
CAS/SASS France	Rocheford du Gard	As Sched.	33 (0) 607 269 373	Marshall Dundee	Golden Trigger of Freetown
East Valley	Dettwiller	As Sched.	06 76 49 54 81	Cornelius Chesterfield	Club de Tir de la Licorne
Golden Trigger of Freetown	Puylagarde	As Sched .	06-75-70-36-78	Cheyenne Little Colibris	A.S.T.P.V
Greenwood Creek Gang	Cogolin, France	As Sched	33688091360	Handy Hook	N/A
Joly's Saloon	Bernay	As Sched.	06 08 83 89 36	Myra Maybelle Shirley Reed Starr	Joly's Saloon
Loire Valley Regulators	Cornery	As Sched	06 83 31 30 53	Yul Tatoo	Club de Tir Sportif de Touraine
Snake Valley	Le Fenti Bernard	As Sched.	06 07 09 5592	Chris T. Bunner	"Champ Blanc"
Old West Gunfighter	Rocheford du Gard	As Sched.	33 (0) 607 269 373	Marshal Dundee	Provenceal de Tir

GERMANY

Cowboy Action Shooting Germany	Edderitz	Last Sat	+49 1609 76 52588	Marshal Heck	Tombstone Village
--------------------------------	----------	----------	-------------------	--------------	-------------------

ITALY

Western Club Canne Tonanti	Verano Brianza	As Sched. Sun	+393493276203	Bruce Miller	A.S.D. Traversera Shooting Club
----------------------------	----------------	---------------	---------------	--------------	---------------------------------

LUXEMBOURG

SSASS Luxembourg	Varies	As Sched	00352 691 161 580	Katie Lou	SSCK
------------------	--------	----------	-------------------	-----------	------

NEW ZEALAND

Ashburton Pistol Club	Ashburton	3rd Sun	+64 21 525 347	Kiwi Witch Doctor	Ashburton Pistol Club
Ashburton Pistol Club Wild Bunch Shooting	Ashburton	3rd Sun PM	N/A	Kiwi Witch Doctor	Ashburton Pistol Club
Bullet Spittin' Sons O' Thunder	Palmerston North	2nd Sat	+64 275221920	Calamity Carrie	Rifle Rod & Gun Club Manawata Inc.
Green Mountain Boys	Upper Hutt	1st Sun	+64 274 221 551	Bald Eagle	Kaitoke Pistol Club
SASS Pistol New Zealand	Hastings	As Sched.	+64 34 38 9696	Lindis Ranger	New Zealand Pistol Association

POLAND

SASS Polish Western Shooting Association	Lodz	As Sched	+48605100315	Crazy Zebra	1st Western Shooting Range
--	------	----------	--------------	-------------	----------------------------

SLOVAKIA

Slovak Western Shooting Association	Domaniza	As Sched.	00421903667096	Bambino	Shooting range Domaniza
-------------------------------------	----------	-----------	----------------	---------	-------------------------

SOUTH AFRICA

Western Shooters of South Africa	Simon's Town	3rd Sat	+27 826522150	Dusty Devil	False Bay Gun Club
----------------------------------	--------------	---------	---------------	-------------	--------------------

SWITZERLAND

Old West Shooting Society Switzerland	Kreuzlingen	As Sched	+41 79 909 92 70	Texas Knight	N/A
---------------------------------------	-------------	----------	------------------	--------------	-----

UNITED STATES OF AMERICA

ALABAMA

North Alabama Regulators	Woodville	1st Sun	256-504-4366	Buck D. Law	Cavern Cove Competition Shooting Range
Old York Shootists	Blountsville	2nd & 4th Sun	205-616-9395	Derringer Di	Old York Shootists Cowboy Action Shooting Range

ALASKA

AAlaska 49er's	Palmer	2nd Sat & 4th Sun	907-982-5017	Flaco Joe	Mat-Valley Sportsmans Shooting Range
Alaska 49ers Wild Bunch	Palmer	2nd Sat	907-982-5097	Flaco Joe	Mat-Valley Sportsmans Shooting Range
Golden Heart Shootist Society	Fairbanks	2nd & 4th Sun	907-978-2296	Montana Kid Hammer	Fox Outdoor Range
Juneau Gold Miners Posse	Juneau	3rd Sun	907-500-9735	Coho Cowboy	Hank Harmon Rifle Range

ARIZONA

Arizona Cowboy Shooters Association Inc	Phoenix	2nd Sat	949-525-7124	Tombstone Sallie	Ben Avery Shooting Facility
Arizona Yavapai Rangers	Camp Verde	4th Sat	928-202-0044	Kirk James	Forest Service Road 9571
Bordertown, Inc.	Tombstone	As Sched	520-290-8599	Quicksand	Tombstone Livery
Colorado River Shootists	Yuma	4th Sun	760-662-3495	Charity Rose Lee	Adair Range

CLUB NAME	CITY	MATCH DAY	PHONE	CONTACT	RANGE LOCATION
Cowtown Cowboy Shooters	Peoria	1st Sun & 3rd Sat	480-773-2753	Barbwire	Cowtown Shooting Range
Cowtown Wild Bunch Shooters	Peoria	4th Sun	602-721-3175	Wild Bodie Tom	Cowtown Shooting Range
Dusty Bunch Old Western Shooters	Casa Grande	4th Sat	520-568-2852	Squibber	Casa Grande Shooting Range
Granite Mountain Outlaws	Chino Valley	3rd Sun	928-963-6515	Tramp	Compass Training Center
NAZty Bunch	Flagstaff	3rd Sat	928-607-5179	Coconino Pistolero	Camp Savage
Rio Salado Cowboy Action Shooting Society	Mesa	1st Sat	602-657-4532	Colt Laredo	Rio Salado Sportsman's Club
Whiskey Row Gunslingers	Prescott	2nd Sun	949-422-9961	Wolfie Lehr	Yavapai Recreation League
White Mountain Old West Shootists	St. Johns	3rd Sat	928-243-4471	Monty Rio	Northeastern Arizona Shooters Association

ARKANSAS

Arkansas Leadslingers	Rogers	2nd Sat & 4th Sat	479-633-2107	Dirty Dan Paladin	Frisco City
Judge Parker's Marshals	Fort Smith/Van Buren	3rd Wknd	479-651-2475	Naildriver	Old Fort Gun Club
Mountain Valley Vigilantes	Hot Springs National Park	1st Wknd	501-337-9368	Bulldog McGraw	Mountain Valley Sportsman's Association
Outlaw Camp	Heber Springs	2nd, 4th & 5th Sat	870-847-0733	Arkansas Harper	Outlaw Camp
White River Gang	Mountain Home	1st & 2nd Sat	719-839-0133	Bayou Bob	Twin Lakes Gun Club

CALIFORNIA

5 Dogs Creek	Bakersfield	1st Sat & Sun	559-707-5316	Buddy Love	Five Dogs Creek Shooting Range
Cajon Cowboys	San Bernadino	2nd, 4th, & 5th Sat	760-900-5199	Pasture Patti	Route 66 Shootings Sports Park
California Rangers	Sloughhouse	2nd Sat	916-606-9051	Juss Slim	Sacramento Valley Shooting Center
California Shady Ladies	Sloughhouse	4th Sat	916-952-1013	Lady Gambler	Sacramento Valley Shooting Center
Canyon Oaks Shootists	Sylmar	2nd Wknd	626-644-5368	Dusty Sagerider	Canyon Oaks Sportsmans Club
Chorro Valley Regulators	San Luis Obispo	2nd Sun & Prec. Sat	805-286-1188	Sinful	San Luis Obispo Sportsman's Association
Coyote Valley Sharpshooters	Morgan Hill	3rd Sat	510-862-8000	Calamity Carl	Santa Clara Courtny Sports Park
Escondido Bandidos	Escondido	1st Sat	760-745-9249	Double Diamond	Escondido Fish & Games Assoc.
Gold Country Wild Bunch	Sloughhouse	3rd Sat	925-783-3800	Tully Mars	Sacramento Valley Shooting Center
Helladorado Rangers	Ukiah	3rd Sunday	707-391-5991	Lead Nickel	Ukiah Gun Club
High Desert Cowboys	Palmdale	3rd Sun	661-579-6917	Doc Silverhawks	Desert Marksmen Rifle & Pistol Club
High Sierra Drifters	Rail Road Flat	2nd Sun	510-703-8064	Grizzly Peak Jake	West Point Rod & Gun
Kings River Regulators	Clovis	3rd Sun	559-352-9829	Big Bad Blaine	Fresno Rifle & Pistol Club
Mother Lode Shootist Society	Jamestown	1st Sun	209-795-4175	Sioux City Kid	Mother Lode Gun Club
Murieta Posse	Sloughhouse	3rd Sun	510-703-8064	Grizzly Peak Jake	Sacramento Valley Shooting Center
Outlaws "The"	Sloughhouse	1st Sat	916-216-0168	Sheriff Wil Katchum	Sacramento Valley Shooting Center
Pozo River Vigilance Committee at Lazy Arrow	Santa Margarita	4th Sat	805-801-8750	Roger Rapid	Camatta Ranch/Lazy Arrow Adventures
Robbers Roost Vigilantes	Ridgecrest	3rd Sat	760-301-4520	Nasty Newt	Ridgecrest Gun Range
The Cowboys	Corona	4th Sun	949-235-4437	Razorback Red	Raahauge Shooting Enterprises

COLORADO

Briggsdale County Shootists	Briggsdale	2nd & 4th Sat & 5th Sun	970-493-1813	Kid Bucklin	Pawnee Sportsmens Center
Colorado Cowboys	Lake George	1st Sat	719-689-2272	Clay Britches	M Lazy C Ranch
Colorado Shaketails	Hanover	1st Sun	719-338-5912	Shootin Hoosier	Frontier Sportsman's Club
Montrose Marshals	Montrose	2nd Sun	970-240-0419	Silver Rings	Montrose Rod & Gun Club
Northwest Colorado Rangers	Craig	4th Sat	970-201-4773	Black Mountain Cat	Bears Ears Sportsman Club
Pueblo West Vigilantes	Pueblo West	2nd Sat	719-545-9463	Grizz Bear	Pueblo West Sportsmen's Assoc.
Rockvale Bunch	Rockvale	3rd Sat	719-252-5970	Cat Tracker	Rockvale Gun Club
Thunder Mountain Shootists	Whitewater	3rd Sat & Sun	970-270-4853	Pinto Being	William Jarvis Shooting Complex

CONNECTICUT

CT Valley Bushwhackers	Coventry	2nd Sat	860-384-0543	Double Tap Taylor	Manchester Sportsman Association
Ledyard Sidewinders	Ledyard	1st Sat	860-608-0916	Yosemite Gene	Ledyard Sportsman's Club

DELAWARE

Paden's Posse	Bridgeville	3rd Sun	302-841-8727	Cool Hand Lee	Bridgeville Rifle and Pistol Club
---------------	-------------	---------	--------------	---------------	-----------------------------------

FLORIDA

Big Bend Bushwhackers	Woodville	3rd Sat	850-320-4411	Deadeye Davis	Tallahassee Rifle and Pistol Club
Cowford Regulators	Jacksonville	4th Sat	904-316-0644	Misfire Mordecai	Gateway Rifle and Pistol Club
Doodle Hill Regulators	Ruskin	4th Sun	910-797-7110	Shelleen	Gun Craft Inc. Range

CLUB NAME	CITY	MATCH DAY	PHONE	CONTACT	RANGE LOCATION
Fort White Cowboy Cavalry	Fort White	2nd Sat	352-222-4214	Confederate Colt	Fort White Gun Club
Hernando County Regulators	Brooksville	1st Sun	517-622-4372	Shoulda Dun Gun	Hernando Sportsman's Club, Inc.
OK Corral Outlaws	Okeechobee	4th Sat	863-357-2226	Kokomo Kid	OK Corral Gun Club
Okeechobee Marshals	Sebastian	2nd Sat	561-371-5507	Amaduelist	Indian River County Shooting Range
Panhandle Cattle Company	Chipley	4th Sat	850-638-4939	Desperado Dale	Panhandle Cattle Company
Panhandle Cowboys	Holt	2nd Sun	850-932-3955	Jeb Stuart Foley	Element Training Complex
Red Hills Rangers	Midway	2nd Sat	850-482-1535	Hollifer A. Dolar	Talon Range
Roughshod Raiders	Gainesville	1st Sat	352-317-2357	Delta Glen	Gainesville Target Range, Inc.
Southwest Florida Gunslingers	Punta Gorda	3rd Sat & 4th Sun	239-772-7994	Vaquero Tom	Hansen Range and Gun Club
Weewahotee Vigilance Committee	Orlando	2nd Sat	407-729-8057	Dead-Aim Dave	Central Florida Rifle and Pistol Club

GEORGIA

Cherokee Cowboys	Gainesville	4th Sat	845-401-0902	Dirty Redd	Cherokee Gun Club
Georgia Mountain Piedmont Regulators	Eastanollee	2nd Sat	706-714-8441	Iron Chief	Georgia Mountain Shooting Association
South River Shootists	Covington	3rd Sat	404-405-8266	Fast Eddie	South River Gun Club
Tennessee Mountain Marauders	Ringgold	3rd Sat	423-593-3767	Double Barrel	Phoenix Farms

HAWAII

Maui Marshals	Lahaina	1st & 3rd Sat	808-870-1796	Shoo-fly Kid	Valley Isle Sport Shooters Club
---------------	---------	---------------	--------------	--------------	---------------------------------

IDAHO

Eagle Rock Regulators	Idaho Falls	1st Sat	208-520-8824	Missouri Ruffian	Southeast Idaho Practical Shooters
Hells Canyon Ghost Riders	Moscow	3rd Sat	208-882-1888	Zebra Dunn	Bernard Peterson Memorial Range
Oregon Trail Rough Riders	Kuna	2nd Sun & 3rd Sat	503-953-5643	Nels Gandy	Black's Creek Rifle Range

ILLINOIS

Border Bandits	Rockford	4th Saturday	815-721-2282	Dry Fire	NIRPC
Illinois River City Regulators	Chillicothe	2nd Sun	309-243-7236	Granville Stuart	Chillicothe Sportsmen's Club
Illowa Irregulars	Milan	3rd Sun	563-349-2273	Rootin Tootin	Milan Rifle Club
Kaskaskia Cowboys	Sparta	2nd Sat	618-534-3548	Okaw	World Shooting and Recreation Complex
Lakewoods Marshals	Rinard	1st Sat	618-262-6948	Rusty Banker	Lakewoods Marshals Cowboy Action Shootin Club Range
McLean County Peacemakers	Bloomington	3rd Sat	309-379-4331	Marshall R. D.	Darnalls Gun Works & Range
Vermillion River Long Riders	Streator	2nd Sunday	815-303-4555	Lead Poison Lar	Sandy Ford Sportsman Club

INDIANA

Paradise Pass Regulators	Erna Green	1st Sat	574-354-7186	C. C. Top	Paradise Pass
Wabash Rangers	Cayuga	4th Sat	217-267-2820	Henry Remington	Clark's Shooting Range
Westside Renegades	Evansville	4th Sat	812-459-2153	Tinhorn Timmy	Westside Sportsmen's Club
Wolff's Rowdy Rangers	Bristol	3rd Sat	574-536-4010	Justice D. Spencer	Chief Wa-Ke-De Range

IOWA

Fort Des Moines Rangers	Indianola	1st Sun & 3rd Sat	641-660-2452	John Wesley Hardin	Central Iowa Shooting Sports
Outlaw's Run	Red Oak	2nd Sun	712-621-5726	Capt. Jim Midnight	Red Oak
Turkeyfoot Cowboys	Waterloo	1st Sat	319-361-2131	Fence Cutter	Turkeyfoot Long Rifles Range

KANSAS

Butterfield Gulch Gang	Chapman	1st Sun & 3rd Sat	785-479-0416	Flinthills Dawg	Clark's Station
Capital City Cowboys	Topeka	4th Sun	785-313-0894	Top	Capital City Gun Club
Chisholm Trail Rowdys	Benton	4th Sun	785-224-4918	Chisholm Kid	Chisholm Trail Antique Gun Association
Free State Rangers	Parker	1st Sun, 3rd Sat, & 5th Sun	913-244-4960	Beans Haney	N/A
Powder Creek Cowboys	Lenexa	2nd & 4th Sat & 4th Wed	913-209-3836	Cooncan	Powder Creek Shooting Park
Powder Creek Cowboys Wild Bunch	Lenexa	5th Sat	913-680-5757	High Plains Hud	Powder Creek Shooting Park

KENTUCKY

Hooten Old Town Regulators	Mckee	1st Sat	859-230-3693	Lyn Ike	Hooten Old Town
Kentucky Long Rifles Cowboys	Morehead	2nd Sat	606-462-3278	Longshot Ace	Kentucky Long Rifles Club
Kentucky Regulators	Boaz	1st Sat	270-556-4082	Shenandoah Slim	Kentucky Regulators Gun Club Inc
Knob Creek Gunfighters Guild	West Point	1st Sun	502-551-8174	Hinote	Knob Creek Gun Range
Levisa Fork Lead Slingers	Pikeville	4th Sat	606-424-8706	Escopeta Jake	East Kentucky Sportsman Assoc.

CLUB NAME	CITY	MATCH DAY	PHONE	CONTACT	RANGE LOCATION
LOUISIANA					
Deadwood Marshals	Sorrento	1st & 3rd Sat	504-458-1898	Doc Spudley	Deadwood Marshals
Up The Creek Gang	Lake Charles	2nd & 4th Sat	337-499-5289	Sparky Gal	Lake Charles Gun Club
MAINE					
Maine Marshals	Berwick	As Sched	207-272-7119	Tyler Tornado	Sanford Springvale Fish and Game
MARYLAND					
Damascus Wildlife Rangers	Mt. Airy	2nd Sat	301-253-0578	Dogmeat Dad	Izaak Walton League of America
Ea'sdern Shore Renegades	Sudlersville	1st Sat	610-724-4842	Black Hills Drifter	Delmarva Sportsman's Association
Thurmont Rangers	Thurmont	1st Sun	202-330-8545	Dutch Coroner	Thurmont Conservation and Sportsman Club
MASSACHUSETTS					
Harvard Ghost Riders	Harvard	As Sched.	978-456-6971	Grazer	Harvard Sportsman's Club
MICHIGAN					
Eagleville Cowboys	Central Lake	4th Sat	231-676-0922	One Son of A Gun	Eagleville Ranch
Johnson Creek Regulators	Plymouth	4th Sat	734-320-4941	Sarge	Western Wayne County Conservation Club
River Bend Rangers	Niles	2nd Sat	574-220-3714	Robert Chance Cole	Bend of the River Conservation Club
Rocky River Regulators	Utica	3rd Sun	248-709-5254	Terrebonne Bud	Detroit Sportsmen's Congress
Rocky River Regulators Wild Bunch	Utica	As Sch	248-709-5254	Terrebonne Bud	Detroit Sportsmen's Congress
Saginaw Field and Stream Club	Saginaw	As Sched	989-585-3292	Katie Callahan	Saginaw Field and Stream Club
Sucker Creek Saddle & Gun Club	Breckenridge	3rd Sat.	989-832-8426	Kid Al Fred	N/A
Wolverine Rangers	Kimball	As Sched.	734-612-0570	Sinola Kid	Blue Water Sportsman's Association
MINNESOTA					
Cedar Valley Vigilantes	Morristown	1st & 3rd Sat	612-384-9115	Riverboat Red	Ahlman's Gun Shop
Fort Belmont Regulators	Jackson	3rd Sun	507-822-5214	A J Royal	Des Moines Valley Sportsman's Club
Granite City Gunslingers	Kimball	2nd Sat	952-452-2907	Hillbilly Bert	Kimball Rod and Gun Club
MISSISSIPPI					
Gulf Coast Gunslingers	Lumberton	1st & 3rd Sun	504-722-8988	Cooper York	Lamar County Shooting Range
Mississippi River Rangers	Byhalia	3rd Sun & 4th and 5th Sat	901-490-0183	Jered Maddox	Rabbit Ridge Ranch
MISSOURI					
Bear Creek Volunteers	Walnut Shade	2nd Sat	417-208-9142	Artemus Von Schutze	Liberty Range
Bear Creek Volunteers Wild Bunch	Walnut Shade	1st Sat	417208-9142	Artemus Von Schutze	Liberty Range
Boonville Regulators	Boonville	2nd Sun, 3rd Sat, & 5th Sun	816-686-8881	Dusty Dustem	Boonville Regulators
Butterfield Trail Cowboys	Walnut Shade	1st & 3rd Wed & 2nd Wknd	417-350-5271	Stennett Kid	Ozark Shooters Sports Complex
Butterfield Trail Cowboys Wild Bunch	Walnut Shade	4th Wkd	417-350-5271	Stennet Kid	Ozark Shooters Sports Complex
Central Ozarks Western Shooters	Newburg	3rd Sun	630-841-1686	Irish Jack Daniels	Central Ozarks Pratical Shooters Range
Gateway Area Shootist Society	Barnhart	3rd Sun	314-578-6027	Fat Chance BuckO	Arnold Rifle and Pistol Club
Glad Top Shooters	Squires	3rd Wkd	417-543-0709	Hon. Sgt. Edward Greenwood Hampton	Bar Lazy B Range
The Ozark Posse	Cassville	1st Sat	417-846-5142	Tightwad Swede	N/A
MONTANA					
Sun River Rangers Shooting Society	Augusta	1st Sat/Sun & 4th Sat	406-590-7599	Crusty Curt	N/A
Bitterroot Buckaroos	Hamilton	1st Sat	406-531-4116	May B. Shecann	Whittecar Rifle Range
Black Horse Shootists	Great Falls	Wkd of 3rd Sun	406-868-9737	J. E. B. Stuart Montana	Great Falls Shooting Sports Complex
Gallatin Valley Regulators	Three Forks	2nd Sat	406-539-9400	Gooch Hill Drifter	Manhattan Wildlife Association
Montana Territory Peacemakers	Billings	4th Sat	406-628-8694	Angel	Billings Rod & Gun Club
NEBRASKA					
Eastern Nebraska Gun Club	Louisville	3rd Sat	402-643-5000	Crooked Creek	Eastern Nebraska Gun Club
Lancaster County Bounty Collection Agency	Frith	2nd Sat	402-890-7620	Terry Lane	Nebraska Shooters
NEVADA					
Battle Born Rangers	Fernley	As Sched	775-250-4554	Irish Ike	N/A

CLUB NAME	CITY	MATCH DAY	PHONE	CONTACT	RANGE LOCATION
Desert Desperados	Las Vegas	3rd Sun	702-419-7024	Nasty Nels	Desert Sportsman Rifle and Pistol Club
Nevada Rangers Cowboy Action Shooting Society	Las Vegas	2nd Wknd	702-460-6393	MT Fargo	Clark County Shooting Range
NEW HAMPSHIRE					
Pemi Valley Peacemakers	Holderness	As Sched.	603-620-5001	Dakota Joe	Pemigewasset Valley Fish and Game Club
NEW JERSEY					
Jackson Hole Gang	Jackson	4th Sun	732-928-9028	Bronco Joan	Central Jersey Rifle & Pistol Club
Quinton Mavericks	Quinton	2nd Sun	609-805-0010	Unexpected Bill	Delaware Blues Rifle and Pistol Club, Inc.
Shongum Wiley Coyotes	Oxford	3rd Sun	973-219-9585	Johnny Swan	Shongum Sportsman Association
NEW MEXICO					
Gila Rangers	Mimbres	2nd Sat	575-956-5221	Hands	Fowler Land and Cattle Company
Monument Springs Bushwhackers	Hobbs	4th Sat.	575-408-2177	Curley Bill Jones	Hobbs Gun Club
Rio Grande Renegades	Albuquerque	2nd Wed & 3rd Sat	574-253-2808	Fire Eater	City of Albuquerque Shooting Range Park
Tres Rios Bandidos	Farmington	2nd & 4th Sun	505-402-6031	Pepper Dane	San Juan Wildlife Federation
NEW YORK					
Boot Hill Regulators	Chester	1st Sun	570-296-2032	Tom Payne	Monroe Chester Sportsmen Club, Inc.
Circle K Regulators	Ballston Spa	3rd Sun	315-357-2352	Feany Valentine	Kayaderoseras Fish & Game Club
Circle K Rough Riders Wild Bunch	Ballston Spa	As Sch	315-357-2352	Feany Valentine	Kayaderoseras Fish and Game Club
East End Regulators	West Hampton Beach	1st Sun	516-729-0381	Deuces	Long Island Practical Shooters, Inc.
Holiday's Rough Riders	Blasdell	5th Sun	716-838-4286	Rev. Dave Clayton	Blasdell Rod and Gun Club
The Long Riders	Shortsville	4th Sun	585-734-0867	Loco Poco Lobo	Shortsville Rod & Gun Club
Tonawanda Cowboys	Pendleton	3rd Sat	716-544-1638	Rusty Rick	Tonawanda Sportsman's Club
NORTH CAROLINA					
Carolina Cattleman's Shooting and Social Society	Creedmoore	2nd Sat	919-791-9816	J. M. Brown	Sir Walter Gun Club
Cross Creek Cowboys	Wagram	3rd Sat	910-470-4891	High Noon Henry	Wagram Sportsmen's Association
Flat Branch Ranch	Bunnlevel	4th Sat	910-624-2624	Twelve Mile Bluff	Range 37 PSR
Iredell Regulators	Statesville	4th Sat	704-677-0554	Tin Can Sailor	Iredell Lodge - FOP #10
Neuse River Regulators	Hevelock	1st & 3rd Sat	252-354-4275	Bronco Kid	Sure Shot Gun Sports
North Carolina Cowboys, Inc.	Salisbury	As Sched.	828-851-1910	Noah Fitz	Rowan County Wildlife Association
NORTH DAKOTA					
Dakota RoughRiders	Moffit	As Sched.	701-223-3085	Rod-Iron-Rip	Fried Family Marksmanship Complex
Shenando Valley Peacekeepers	Enderlin	Last Sat	701-793-4116	Wild River Rose	Shenando Valley Peacekeeper Range
Trestle Valley Rangers	Minot	2nd Sat	701-833-4282	Buffalochip Dave	Minot Rifle and Pistol Club
OHIO					
Big Irons	Middletown	1st Sat	937-866-3795	Three Gun Jake	Middletown Sportman's Club
Blackhand Raiders	Nashport	2nd Sun	614-313-6122	Iron Horse Garrett	Dillon Sportsman Center
Brown Township Regulators	Malvern	Last Sat	330-904-5166	Sixgun Seamus	Brown Township Sportsman's Club
Central Ohio Cowboys	Circleville	4th Sun	614-657-8322	Abe Cross Jackass Jack	Pickaway County Sportsmans Club
Firelands Peacemakers	Rochester	3rd Sat	216-789-7885	Harry Yount	Rochester Rod Range
Greene County Cowboys	Xenia	1st Sun	937-422-4595	Ruger Ray	Greene County Fish & Game Association
Sandusky County Regulators	Gibsonburg	2nd Sat	419-205-0114	Badfinger Bodene	Sandusky County Sportsman's Club
Shenango River Rats	Masury	2nd Sat & Last Thurs	440-693-4210	Slow Mo Dern	Brookfield Tri-District Conservation Club
Wild Wild West Point Cowboy Action Shooting	West Point	2nd Sun	330-386-6975	Blue Eyed Bob	West Point Rod & Gun Club
OKLAHOMA					
Indian Territory Single Action Shooting Society	Tulsa	1st Sun, 3rd Sat, & 4th Wed.	918-508-9381	Slow Hand	Tulsa Red Castle Gun Club
Lincoln County Cowboys	Cushing	1st Sat & 3rd Sun	918-285-0543	Scott Wayne	Crossroads Gun Range
Oklahoma Territorial Marshals	Arcadia	2nd Sat & 4th Sun	405-409-9442	Flat Top Okie	Oklahoma City Gun Club
Red River Valley Cowpokes	Albany	2nd Wknd	580-847-2210	Calamity Di Bar	Red River Valley Cowboy Church
Shortgrass Rangers	Grandfield	1st & 3rd Sat	940-447-6864	Redleg Reilly	N/A
OREGON					
Dry Gulch Desperados	Milton-Freewater	1st Sat	509-520-2789	Pinto Annie	East End Rod & Gun Club

CLUB NAME	CITY	MATCH DAY	PHONE	CONTACT	RANGE LOCATION
Horse Ridge Pistoleros	Bend	1st, 3rd, & 5th Sun	541-389-2342	Big Casino	Central Oregon Shooting Sports Association
Horse Ridge Pistoleros Wild Bunch	Bend	1st, 3rd, & 5th Sun	541-848-7260	Big Casino	Central Oregon Shooting Sports Association
Merlin Marauders Cowboy Action Shooting Possee	Grants Pass	1st Sat & 3rd Sun	707-485-5301	Molly b'Dam	Josephine County Sportsmans Association Park
Old 97 Railroad Rangers	Redmond	2nd Sat	541-548-3198	Tetherow Tex LaRue	Redmond Rod and Gun Club
Oregon Old West Shooting Society	Albany	3rd Sun & 4th Sat	541-760-0884	Barry L Plotz	Albany Rifle & Pistol Club
Oregon Trail Regulators	La Grande	3rd Sat	541-571-4979	T. J. Maverick	La Grande Rifle & Pistol Club Hwy 244, LGRPC
Pine Mountain Posse	Bend	2nd Sun	541-419-4718	Sunrise Bill	Central Oregon Shooting Sports Association
Siuslaw River Rangers	Florence	1st Sun	541-997-6313	Johnny Jingos	Siuslaw Rod and Gun Club
Virtue Flat Shootist Society	Baker City	2nd Sat	541-212-5840	Hunt Mountain Drifter	Powder River Sportsman's Club

PENNSYLVANIA

Black Forest Cowboys	Coudersport	3rd Sat	814-203-1748	Bolo	Black Forest Conservation Association
Blue Mountain Rangers	Hamburg	3rd Sun	610-334-3504	Tombstone Coty	Hamburg Rifle & Pistol Club
Chimney Rocks Regulators	Holidaysburg	2nd Sat	814-695-7064	Colorado Smith	Holidaysburg Sportman Club
El Posse Grande	Muncy Valley	4th & 5th Sun	570-337-3974	Black Hills Barb	North Mountain Sportsman's Association
Elstonville Hombres	Manheim	4th Sun	717-648-7491	Circuit Rider Jeff	Elstonville Sportsman's Association
Jefferson Outlaws	Spring Grove	3rd Sat	443-392-1615	Red-Eyed Kid	Jefferson Rifle Club
Logan's Ferry Regulators	New Kensington	2nd Sat	724-454-3159	Dirt Slider	Logans Ferry Sportsmen's Club
Mainville Marauders	Mainville	2nd Sun	570-690-3932	Dodge Bill	Mainville Sportsman's Club
Matamoras Mavericks	Milford	2nd Sun	570-686-3618	Ziggady Zag	Matamoras Rod & Gun Club
Perry County Regulators	Newport	1st Sat	717-307-6374	Farmer Brown	Ickesburg Sportsmen's Association
Welsh Mountain Regulators	Gap	2nd Sun	484-802-7122	Blaze Crittenden	New Holland Rifle and Pistol Club

RHODE ISLAND

Lincoln County Lawmen	Foster	4th Sun	401-595-0735	Nutmeg Ryder	Pine Tree Gun Club
-----------------------	--------	---------	--------------	--------------	--------------------

SOUTH CAROLINA

Belton Bushwhackers	Belton	2nd Sat	864-363-3147	Slippery Stew	Belton Gun Club
Geehee Gunfighters	Ridgeville	4th Sat	843-737-3501	Doc Kemm	Palmetto Gun Club
Greenville Gunfighters	Greenville	4th Sun	864-420-0577	Abe E.S. Corpus	Greenville Gun Club
Hurricane Riders	Galivants Ferry	3rd Sat	860-593-7566	Black Mike	Horry Chapter Wildlife Action
Savannah River Rangers	Gaston	3rd Sun	803-960-3907	Kid Ray	Mid Carolina Rifle Club

SOUTH DAKOTA

Black Hills Shootist Association	Pringle	3rd Sun	612-817-2212	Boulder Canyon Bob	Pringle Shooting Range
Medicine Creek Road Agents	Oneida	1st Sun	605-222-5145	Iron Mender	Medicine Creek Road Agents Shooting Range

TENNESSEE

Greene County Regulators	Rogersville	1st & 3rd Sat	423-383-3195	Lil Weasel	Greene County Fish & Game Assoc.
Memphis Gunslingers	Lakeland	1st Sun & 2nd Sat	901-831-3676	Buffalo Trace	Memphis Sport Shooting Association
Ocoee Rangers	Cleveland	4th Sat	423-595-3819	Ocoee Red	Cleveland Hunting Rifle & Pistol Club
ORSA's Oak Ridge Outlaws	Oak Ridge	2nd Sat	865-314-0321	Keystone	Oak Ridge Sportsman's Association
Wartrace Regulators	Wartrace	1st & 3rd Sat	931-703-8274	Whiskey Hayes	Regulators Range

TEXAS

Badlands Bar 3	Clarksville	4th Wkd	903-272-9283	T-Bone Dooley	Badlands Bar 3
Butterfield Trail Regulators	Anson	3rd Sat	325-669-5903	Smilin Joe	Anson
Comanche Trail Shootists	Midland	1st Sat	432-557-0860	Tumbleweed Dan	Timberline Ranch
Comanche Valley Vigilantes	Cleburne	4th Wknd	817-980-7206	Shady McLarry	Ormsby Ranch
Concho Valley Shooters	Water Valley	2nd Sat	325-655-3625	Doc Sanders	McDuffie Range
Gruesome Gulch Gang	Plainview	2nd Sat	806-729-5887	Eli Blue	N/A
Highplains Highwaymen	Pampa	3rd Sat	719-510-7307	Howlin Wolf	Wolfpack Ranch
Lone Star Frontier Shooting Club	Cleburne	2nd Wkd	817-774-5637	Hot Tamale	Ormsby Ranch
Oakwood Outlaws	Oakwood	2nd Full Wkd	214-384-3975	Denton Dancer	Shank Ranch
Old Fort Parker Patriots	Groesbeck	3rd Wkd	254-366-2372	Slowaz Molasses	Old Fort Parker Gun Club
Orange County Regulators	Orange	1st & 3rd Sat	409-267-1091	Texas Gator	Orange Gun Club
Plum Creek Shooting Society	Lockhart	1st Sat	210-303-6996	Brazos Bo	Comanche Country Ranch
Rio Grande Valley Vaqueros	Pharr	4th Sun	956-648-7364	Dream Chaser	Pharr Rifle and Pistol Club

CLUB NAME	CITY	MATCH DAY	PHONE	CONTACT	RANGE LOCATION
South Texas Pistoleros	San Antonio	1st	210-213-4812	Latigo Lee	A Place To Shoot Inc.
Tejas Caballeros	Blanco	3rd Sat	210-912-8227	Prickly Pear Peggy	Texas Republic Ranch
Texas Historical Shootist Society	Columbus	3rd Weekend	281-639-4166	Pepper Russel	Brune Ranch
Texas Riviera Pistoleros	George West	2nd & 5th Sat	361-254-0064	Ginger Vitis	Gamble Gulch Range
Texas Ten Horns	Leonard	1st Sat & Sun	972-658-4347	Hairtrigger Hayes	Top Gun Shooting Sports
Texican Rangers	Comfort	2nd Sat & Sun	210-355-5121	Alamo Andy	Adolf Stieler Ranch
Thunder River Renegades	Plantersville	1st & 4th Sat	281-785-2397	Osage Mike	N/A
Willow Hole Cowboys	North Zulch	3rd Sat	979-200-1130	Def Willie	Thomason Ranch

UTAH

Castle Gate Posse	Price	4th Sat	435-650-6544	Fargo Kid	North Spring Shooting Range
Cowboys Of Utah	Salt Lake City	4th Sat	385-237-1861	Longwalker	WASR "Big Salty"
Dixie Desperados	Hurricane	2nd & 4th Sat	435-673-9785	Navajo Kelly	Desperado Canyon
Dixie Desperados Wild Bunch	Hurricane	1st Sat	435-668-4613	Mokaac Kid	Southern Utah Shooting Sports Park
Dixie Desperados/Territorial Wild Bunch	Hurricane	As Sch	801-829-8989	J.T. Wild	Red Rock
Utah Territory Gunslingers	Salt Lake City	1st Sat	801-913-6823	Brer Rabbit	Big Salty
Utah War	Salt Lake City	3rd Sat	801-913-6823	Brer Rabbit	WASR "Big Salty"
Wasatch Summit Regulators	Salt Lake City	2nd Sun	801-966-7522	Harry Trigger	Big Salty

VERMONT

Verdant Mountain Vigilantes	St. Johnsbury	As Sched	802-333-9320	Eyesa Horg	Caledonia Forest and Stream Club
-----------------------------	---------------	----------	--------------	------------	----------------------------------

VIRGINIA

KC's Corral Cowboy Shooting Association	Mechanicsville	2nd Sat	804-382-3407	Bucksaw Bob	Black Creek Gun Club
Mattaponi Sundowners	Shackelfords	3rd Sun & 4th Sat	804-241-5418	Potter County Kid	West Point Gun Club
Pepper Mill Creek Gang	King George	4th Sun	540-775-7417	Justice Deadly	Northern Virginia Gun Club
Rivanna Ranger Company	Charlottesville	2nd Sat	203-216-2316	Captian R. Hugh Kidme	Rivanna Rifle and Pistol Club

WASHINGTON

BNortheast Washington Regulators	Colville	1st Wkd	509-690-4060	A. T. McGee	Ricochet Junction
Pataha Rustlers	Dayton	2nd Sat	509-520-2789	Pinto Annie	Patit Range
Rattlesnake Gulch Rangers	Benton City	4th Sat	509-628-0889	Ricochet Robbie	Tri Cities Shootig Association
Renton United Cowboy Action Shooters	Renton	1st Wkd	425-432-3534	Cedar County Sheriff	Renton Fish & Game Club
Smokey Point Desperados	Arlington	2nd Sun	425-870-0193	Mudflat Mike	Marysville Rifle Club
Wolverton Mountain Peace Keepers	Ariel	3rd Sat (Mar-Sept)	360-901-5688	Evergreen Rose	Wolverton Mountain Gun Club

WISCONSIN

Crystal River Gunslingers	Dayton	2nd Sat	920-722-4105	James Rosewood	Chain O'Lakes Conservation Club
Hodag Country Cowboys	Rhineland	2nd Sat	715-362-2792	Scum Bucket	Hodag Sports Club
Liberty Prairie Regulators	Ripon	3rd Sat	920-896-5128	Dirty Deeds	Ripon Rifle and Pistol Club
Rock River Regulators	Beloit	1st & 3rd Sat	414-659-7650	Saddlespur Kate	Beloit Rifle Club
Western Wisconsin Wild Bunch	Holmen	2nd Sat	608-790-3260	Flyen Doc Koyote	Holmen Rod and Gun Club
Wisconsin Old West Shootists, Inc	Glenwood City	2nd Sun & 4th Sat	715-790-9959	Colonel Carbine	WOWS Station

WEST VIRGINIA

Cowboy Action Shooting Sports	Great Cacapon	4th Sat Mar-Oct	304-289-6098	Last Word	Singing Hills Ranch
Dawn Ghost Riders	Hinton	1st sat	304-832-6550	Blue Ridge Rooster	Dawn Sportsmen's Club
Kanawha Valley Regulators	Eleanor	2nd Sat	304-397-6188	Eddie Rebel	Putnam County Park Gun Club
Kanawha Valley Regulators Wild Bunch	Eleanor	2nd Wkd	304-397-6188	Eddie Rebel	Putnum County Gun Club
White Horse Riders	Volga	2nd Sun	304-838-2791	Jessie May Belle	Whitehorse Firearms and Education Center

WYOMING

Bessemer Vigilance Committee	Casper	1st Sun & 3rd Sat	307-267-1155	Smokewagon Bill	Stuckenhoff Sport Shooters Complex
Border Vigilantes	Cheyenne	3rd Sun	307-287-6733	Assassin	Otto Road Shooting Range
Colter's Hell Justice Committee WSAS	Powell	1st Sat	307-254-2090	Yakima Red	Heart Mountain Rod and Gun Club
Donkey Creek Shootists	Gillette	4th Sun	307-686-7519	Wyoming Gus	Milney Valley Range
Great Divide Outlaws	Rawlins	4th Sat	307-320-7250	Sling Lead	Rawlins Outdoor Shooting Complex

SASS AFFILIATED CLUBS 2022 ANNUAL MATCHES

CLUB NAME	DATE	CONTACT	PHONE	EMAIL	CITY	ST	MONTH	WEB
AUSTRALIA								
Dalby Pioneers Easter Shoot	4/17 - 4/17	Mrs. H	+0458 510 122	mrs_h38@hotmail.com	Dalby	QL	April	N/A
SASS Australian Regional Championship	10/1 - 10/2	R. C. Shot	+61 447 831 154	russell.behrens@mmem.com.au	N/A	QL	October	www.ssaa.org.au
AUSTRIA								
Gunfight in Stonewell	4/29 - 4/29	Fra Diabolo	+43 (0) 664 49 80 32	fra.diabolo@sass-austria.at	Steinbrann	—	April	www.sass-austria.at
CANADA								
Shootout At The Ridge	5/20 - 5/22	Goldie Stone	778-241-5538	margfair@earthlink.net	Mission	BC	May	www.rustywood.ca/rmr/rmr.html
SASS Eastern Canadian Wild Bunch Regional Championship	7/13 - 7/14	Serenity / Legendary Lawman	905-393-4299	peterandliz2012@gmail.com	London	ON	July	www.crumlin.org
SASS Eastern Canadian Regional Championship	7/15 - 7/17	Currahee Kid	519-860-2004	ecasc539@rogers.com	London	ON	July	www.crumlin.org
Shoot Out on the North Saskatchewan	7/23 - 7/24	Alberta Jayhawk	780-977-5977	jtrenaman@shaw.ca	Leduc County	AB	July	https://historical-arms.com
Showdown in the Valley	7/29 - 8/1	Little Edgy	250-897-2194	edgy52@gmail.com	Courtenay	BC	July	www.valleyregulators.com
SASS WESTERN CANADIAN REGIONAL CHAMPIONSHIP Shootout at Bounty Gulch	8/3 - 8/6	Wild Whiskey Wade	306-230-3788	trentunterreiner@live.ca	Saskatoon	SK	August	www.sawws.com
Show Down on the Macleod Trail	8/18 - 8/21	Alberta Annie	403-687-2284	kranches@platinum.ca	Granum	AB	August	N/A
Headquarters Shootout	8/26 - 8/28	Black Ashley	250-744-4705	ash_man@shaw.ca	Victoria	BC	August	www.vfpa.org/shooting/cowboy-action/
SASS Canadian National Wild Bunch Championship	8/31 - 9/1	Burt the Undertaker	250-230-0234	firemen164@yahoo.ca	Courtenay	BC	August	www.valleyregulators.com
SASS CANADIAN NATIONAL CHAMPIONSHIP Bustup at Boomtown	9/2 - 9/4	Whistlin Will	250-650-2947	Whislwinwill@gmail.com	Courtenay	BC	September	www.bustupatboomtown.ca
FINLAND								
The North Star Trail	7/14 - 7/17	Captain Woodbury Kane	+358505174659	cassino@elisanet.fi	Loppi	—	July	www.cows.fi
NEW ZEALAND								
End of the Trail	10/21 - 10/23	Calamity Carrie	+64275221920	carolyn.fulton@xtra.co.nz	Palmerston	—	October	N/A
UNITED STATES OF AMERICA								
Comancheria Days	4/6 - 4/9	Alamo Andy	210-355-5121	bmuehlstein@att.net	Comfort	TX	April	www.texicanrangers.org
SASS South Carolina State Championship The Bushwhack	4/7 - 4/9	Slippery Stew	864-363-3147	slipperystew1229@gmail.com	Belton	SC	April	www.beltonbushwhackers.com
Shootout at Fort Miller	4/14 - 4/16	Snakebite	559-999-9715	snakebite4767@yahoo.com	Clovis	CA	April	www.kingsriverregulators.com
SASS Western Territorial Wild Bunch Championship	4/18 - 4/19	Mokaac Kid	435-668-4613	mokaackid@gmail.com	Hurricane	UT	April	www.dixiedesperados.com
SASS Four Corners Regional	4/20 - 4/23	Mokaac Kid	435-668-4613	mokaackid@gmail.com	Hurricane	UT	April	www.dixiedesperados.com
SASS North Carolina Black Powder State Championship	4/20 - 4/20	Noah Fitz	828-851-1910	Noahfitz.ncci@yahoo.com	Salisbury	NC	April	SASSncowboys.com
SASS Washington State Championship Rattlesnake Gulch Roundup	4/21 - 4/24	Crisco	509-628-0889	mensminger250@gmail.com	Benton City	WA	April	www.rattlesnakegulch.org
Gunfight at Arroyo Cantua	4/21 - 4/24	Nyack Jack	916-812-0434	nyackjack2lady@aol.com	Sloughouse	CA	April	www.cagunslingers.com
SASS Kentucky State Match- Shootout in the Hills	4/21 - 4/23	Copperhead Joe	606-599-5263	jeromejarvis61@gmail.com	Manchester	KY	April	www.ponderosa-pines.com
Gunfight at Arroyo Cantua	4/21 - 4/24	Nyack Jack	916-812-0434	nyackjack2lady@aol.com	Sloughouse	CA	April	www.cagunslingers.com
Mayhem on the Mountain	4/22 - 4/24	Arkansas Harper	870-847-0733	arkansas Harper@yahoo.com	Heber Springs	AR	April	www.outlawcamp.org
SASS Oklahoma State Wild Bunch Championship Red Dirt	4/22 - 4/24	Hondo Tweed	405-694-5270	hondotweed@gmail.com	Arcadia	OK	April	cowboyokcgunclub.org
SASS Alabama State Championship Shootout At Cavern Cove	4/28 - 4/30	Buck D. Law	256-504-4366	don.carlton@arrowgraphics.net	Woodville	AL	April	www.northalabamaregulators.com
SASS California State Championship Legends of the West	4/28 - 5/1	Beartrap	909-810-0225	beartrap@earthlink.net	Devore	CA	April	www.cajoncowboys.com
SASS Delaware State Championships	4/29 - 5/1	Corkscrew Tom	410-251-2392	corkscrewtom23@gmail.com	Bridgeville	DE	April	www.brpc-de.com
Rootin' Tootin' Shootout II	4/30 - 4/30	Diamond Lilly	601-594-7992	marty@coffeeneewjackson.com	Mendenhall	MS	April	www.mississippipeacemakers.net
Ambush at Ricochet Junction	5/6 - 5/8	Ranger Six	509-467-0553	gsfarris@yahoo.com	Colville	WA	May	www.newregulators.com/
SASS Kansas State Championship	5/6 - 5/8	Flints Hills Dawg	785-479-0416	dawgpownd@eaglecom.net	Chapman	KS	May	www.butterfieldgulch.com
Raid by the Lake	5/7 - 5/7	Double Diamond	760-745-9249	dbrinkmeier1@cox.net	Escondido	CA	May	www.escondidobandidos.org
Spring Round Up	5/12 - 5/14	Persimmon Dan	812-453-3168	olddanriver@twc.com	Evansville	IN	May	westsidesportsmans.com/committees/cowboy-sass/
For the Heck of it	5/13 - 5/15	Pinto Annie	509-520-2789	pintoannie@cowboybullets.com	Dayton	WA	May	ccshooting.com
SASS West Virginia State Blackpowder Championship Smoke over Buffalo Flats, XIII	5/14 - 5/15	Eddie Rebel	304-397-6188	ecclark@suddenlink.net	Eleanor	WV	May	www.kanawhavalleyregulators.com
SASS Alaska State Wild Bunch Championship Shootout at Moose Nugget Flats	5/14 - 5/15	Marshal Stone	907-232-1080	walling@mtaonline.net	Palmer	AK	May	www.alaskacowboyshooting.com
Shootin' for the Brand	5/14/ - 5/14	Calamity Di Bar	580-847-2210	dibartoma@mc.com	Albany	OK	May	rrvcowpokes.weebly.com
Middle of the Road	5/14 - 5/15	Nels Gandy	503-953-5643	nelsgandy@gmail.com	Boise	ID	May	idahocowboyaction.org
SASS California State Wild Bunch Championship	5/19 - 5/22	Tully Mars	925-783-3800	lockettbryan@yahoo.com	Sloughouse	CA	May	www.cagunslingers.com
SASS Georgia State Blackpowder Championship Smokeout at South River	5/19 - 5/19	Fast Eddie	404-405-8266	fasteddie76308@hotmail.com	Covington	GA	May	www.srscowboy.com
SASS Georgia State Championship Stampede at South River	5/19 - 5/21	Fast Eddie	404-405-8266	fasteddie76308@hotmail.com	Covington	GA	May	www.srscowboy.com
Whoopiri' Ass	5/20 - 5/22	Prickly Pear Peggy	210-912-8227	pjhuddleston@att.net	Blanco	TX	May	http://tejasballeros.net/
SASS Washington State Blackpowder Championship	5/20 - 5/22	Copenhagen Kid	509-863-4501	nativesniper@comcast.net	Medical Lake	WA	May	windy-plains-drifters.com
Southeastern NM Shootout	5/20 - 5/21	Curley Bill Jones	575-408-2177	matttray1220@yahoo.com	Hobbs	NM	May	msbushwhackers.com
Thunder in the Brush	5/21 - 5/22	Bucksaw Bob	804-382-3407	uncleobert@msn.com	Mechanicsville	VA	May	www.kscorral.net

CLUB NAME	DATE	CONTACT	PHONE	EMAIL	CITY	ST	MONTH	WEB
Spring Roundup	5/21 - 5/22	Beans Haney	913-244-4960	mhaney715@gmail.com	Parker	KS	May	freestaterangers.com
SASS Utah State Blackpowder Championship	5/21 - 5/21	Fargo Kid	435-650-6544	urfargokid@yahoo.com	Price	UT	May	www.thecastlegetoposse.net/
High Sierra Shoot Out	5/23 - 5/29	Chance McCall	916-425-5018	tom@tvsypainting.com	Rail Road Flat	CA	May	https://cagunslingers.com/
SASS Mississippi State Championship Smokin' Guns at Rabbit Ridge	5/26 - 5/30	Jackalop Job	662-618-8278	jackalopejob@att.net	Byhalia	MS	May	mississippiriverrangers.org
SASS Ohio State Championship Shootout at Hard Times	5/26 - 5/29	Mean Gun Mark	937-219-4376	meangunmark@earthlink.net	Piqua	OH	May	www.miamivalleycowboys.org/
SASS Pennsylvania State Championship North Mountain Shoot Out	5/27 - 5/29	Black Hills Barb	570-337-3974	basnyder1@comcast.net	Muncy Valley	PA	May	www.elpossegrande.com
The Geronimo Trail Shootout	5/27 - 5/30	Hands	575-956-5221	handscollins@gmail.com	Mimbres	NM	May	www.gilarangers.com/
SASS Iowa State Championship Shootout at Coyote Gulch	5/27 - 5/29	Tuco	515-988-2301	acardenas32755@gmail.com	Indianola	IA	May	www.fortdesmoinesrangers.com
End Of Road	5/27 - 5/29	Missy Mable	208-731-6387	missymable3232@gmail.com	Twin Falls	ID	May	www.idahocas.net
Where the Old West Stayed Young	5/28 - 5/29	Sagebrush Burns	970-208-3196	270burns@gmail.com	Craig	CO	May	www.bearsars.org
SASS Oregon State Championship	5/28 - 5/30	Arctic Annie	541-588-2722	tpalmer@wini.com	Redmond	OR	May	https://trandgc.com/index.php/cowboy
May Mayhem	5/28 - 5/29	Pecos Steve	417-770-7516	skopecs@yahoo.com	Marshfield	MO	May	www.so-mo-rangers.com
SASS Tennessee State Championship	6/2 - 6/4	Whiskey Hayes	931-703-8274	Bill_May@b-f.com	Wartrace	TN	June	www.wartraceregulators.com
Ghost Town of the West	6/2 - 6/4	El Juez	N/A	judgefarr@gmail.com	Salt Lake City	UT	June	www.utahwar.com
Reckoning on the Rock	6/3 - 6/5	Turkey Legs	815-721-2280	spis4@hotmail.com	Beloit	WI	June	www.rockriverregulators.com/
SASS MA, CT, and RI State Championship	6/3 - 6/5	Yankee	781-985-0183	yankeesas266@gmail.com	Harvard	MA	June	www.harvardghostriders.com
Shootout at the Painted Desert	6/4 - 6/5	Monty Rio	928-243-4471	bco173rd@yahoo.com	St. Johns	AZ	June	www.wmows.com
The Great Spagetti Western	6/4 - 6/5	Kid Ricky Bobby	214-507-7993	pacekeith@yahoo.com	Leonard	TX	June	www.texas10horns.org
SASS Battle for Baldknobbers Ridge	6/4 - 6/5	Arretmus Von Schutze	417-208-9142	bearcreekvol@gmail.com	Walnut Shade	MO	June	bearcreekvolunteers.com/
The Prince of Pistoleros	6/9 - 6/11	Cooncan	913-209-3836	cooncan.pcc@gmail.com	Lenexa	KS	June	www.powdercreekcowboys.com
SASS Indiana State Championship Ambush at Paradise	6/10 - 6/12	C. C. Top	574-354-7186	curtbaguns@gmail.com	Erna Green	IN	June	www.paradisepasregulators.com/
SASS Maryland State Championship Thunder Valley Days	6/10 - 6/12/	Dogmeat Dad	301-253-0578	cnlimparis@compuserve.com	Damascus	MD	June	www.wildlifangers.com
SASS New York State Wild Bunch Championship Muster At Fort Misery	6/11 - 6/12	Renegade Roper	518-275-1342	dischenaf6@gmail.com	Ballston Spa	NY	June	www.circlekregulators.com
SASS North & South Dakota State Championship Peace in the Valley	6/16 - 6/19	Wild River Rose	701-793-4116	wildriverrose5@aol.com	Enderlin	ND	June	www.sheyenvalleypeacekeepers.com
SASS Colorado Wild Bunch State Championship	6/16 - 6/17	Kodiak Kid	970-417-6247	kodiak35294@yahoo.com	San Juan	CO	June	sanjuanshootingrange.com
SASS Colorado State Championship Revenge at San Juan City	6/17 - 6/19	Kodiak Kid	970-417-6247	kodiak35294@yahoo.com	Montrose	CO	June	sanjuanshootingrange.com
SASS Oregon State Wild Bunch Championship	6/17 - 6/19	Texas Jack Morales	451-420-3955	guntraders@gmail.com	Bend	OR	June	www.hrp-sass.com/
SASS Western Frontiersman Territorial Match	6/17 - 6/19	Tully Mars	925-783-3800	lockettbryan@yahoo.com	Sloughhouse	CA	June	www.cagunslingers.com
Gunfight on the Prairie	6/18 - 6/18	Dirty Deeds	920-896-5128	popcorn1@charter.net	Ripon	WI	June	www.ripongunclub.com
Women's Wild West Shootout & Silver Screen Shootout	6/19 - 6/20	Ozark Belle/ Ozark Shark	573-502-9219	tracygar@charter.net/ theozarkshark@gmail.com	Marshfield	MO	June	www.so-mo-rangers.com
Battle at Adobe Walls	6/24 - 6/26	Howling Wolf	719-510-7307	wolfpow@msn.com	Pampa	TX	June	www.highplainshighwaymen.com
SASS Virginia State Blackpowder Championship Smoke on the Mattaponi	6/25 - 6/25	Potter County Kid	804-241-5418	97graves@gmail.com	West Point	VA	June	www.westpointgunclub.com
SASS Wisconsin State Blackpowder Championship Smoke in the Hills	6/25 - 6/26	Tracker Jack Daniels	715-643-2011	trackerjackdaniels@gmail.com	Glenwood City	WI	June	www.wowsinc.org
SASS Alaska State Championship Shootout Under The Midnight Sun	7/1 - 7/3	Marshal Stone	907-232-1080	walling@mtaonline.net	Palmer	AK	July	www.alaskacowboysshooting.com
Independence Day Shoot-Out	7/2 - 7/3	Johnny Jingos	541-997-6313	johnnyjingos@yahoo.com	Florence	OR	July	www.suslawgunclub.com/
SASS Idaho State Championship Renegade Shootout	7/7 - 7/9	Nels Gandy	503-953-5643	nelsgandy@gmail.com	Boise	ID	July	idahocowboyaction.org
Shootout On the Sun River	7/8 - 7/11	Robert Powers	406-231-0805	robertpowers4@bresnqn.net	Augusta	MT	July	www.sunriverangers.weebly.com
SASS Minnesota State Championship North Star Showdown	7/9 - 7/10	Hillbilly Bert	952-452-2907	hillbillybert@outlook.com	Kimball	MN	July	www.gcgunslingers.com/
Black Gold Shootout	7/13 - 7/16	Copperhead Joe	606-599-5263	jeromejarvis61@gmail.com	Manchester	KY	July	www.ponderosa-pines.com
SASS Utah State Championship	7/14 - 7/16	The Wolf of North Springs	435-650-4449	scotto4570@gmail.com	Price	UT	July	www.thecastlegetoposse.net/
SASS Montana State Championship Battle at Black Horse	7/14 - 7/17	J.E.B Stuart Montana	406-727-7625	dlfjaf@charter.net	Great Falls	MT	July	www.blackhorseshootists.com
Oregon Trail Shootout	7/15 - 7/17	T. J. Maverick	541-571-4979	tjmaverick@charter.net	La Grande	OR	July	www.lgrpc.com
SASS Illinois State Championship	7/15 - 7/17	Popcorn Kelly	563-650-4606	bohlm@outlook.com	Milan	IL	July	www.illowairregulars.com
The Long Riders Annual 3 Day Shoot	7/22 - 7/24	Loco Poco Lobo	585-734-0867	locopocolobo@gmail.com	Shortsville	NY	July	www.long-riders.org/
SASS Missouri State Blackpowder Championship Outlaw Range Mid-Summer Shootout	7/23 - 7/24	Longshot John	417-299-7635	easymav12@yahoo.com	Marshfield	MO	July	www.so-mo-rangers.com
SASS Michigan Wild Bunch State Championship Shootout at Bloody Porch	7/23 - 7/23	Sinola Kid	734-612-0570	sinolakid@gmail.com	Saginaw	MI	July	www.wolverinerangers.org
SASS Wisconsin State Wild Bunch Championship	7/23 - 7/24	Colonel Carbine	715-790-9959	garoth1961@gmail.com	Glenwood City	WI	July	www.wowsinc.org
Annual Roundup	7/29 - 7/31	Rowdy Rex	503-866-8993	strick747@frontier.com	Canby	OR	July	www.canbyrodandgunclub.org
SASS Ohio Black Powder State Championship Blackout at Stoney Bottom	7/30 - 7/30	Woody Shootem	419-704-3106	woodyshootem@frontier.com	Gibsonburg	OH	July	www.ourcowboys.org
West Match	8/5 - 8/7	T-Bone Shorty	425-503-9919	terrysporrang@comcast.net	Renton	WA	August	www.rucasocowboys.com/
Badger Mountain Range War	8/5 - 8/7	Clay Britches	719-689-2272	seth@myvypma.com	Lake George	CO	August	www.coloradocowboys.net
Mason Dixon Stampede	8/5 - 8/7	Dutch Coroner	202-330-8545	dutchcoroner82128@gmail.com	Thurmont	MD	August	www.thurmontangers.com
SHOOTOUT at ELK RUN	8/5 - 8/7	Fence Cutter	319-361-2131	rsbetka@gmail.com	Waterloo	IA	August	www.turkeyfoot.org
Atomic Gunfight	8/5 - 8/6	Missouri Ruffian	208-520-8824	cptv8ng4570@gmail.com	Idaho Falls	ID	August	www.scips.org
SASS WESTERN REGIONAL CHAMPIONSHIP Chorro Valley Shootout	8/10 - 8/14	Sinful	805-286-1188	michaelgarripee@yahoo.com	San Luis Obispo	CA	August	https://chorrovalleyregulators.com/
SASS NORTHWEST REGIONAL CHAMPIONSHIP	8/10 - 8/14	Missy Mable	208-731-6387	missymable3232@gmail.com	Jerome	ID	August	www.idahocas.net
SASS NORTHEAST REGIONAL Championship Guns of August	8/12 - 8/14	Lassiter	937-687-1039	lassiter45@aol.com	Middletown	OH	August	www.bigirons.com
Annual 2 Day Camp & Match	8/18 - 8/20	Riverview Rattler	989-400-1057	mpjdon@gmail.com	Breckenridge	MI	August	www.SuckerCreek.org
Besemer Jail Break	8/19 - 8/21	Smokewagon Bill	307-267-1155	hooverpatwilliam@hotmail.com	Casper	WY	August	N/A
SASS New Hampshire State Championship Fracas at Pemi Gulch	8/19 - 8/21	Dakota Joe	603-620-5001	dakota814@msn.com	Holderness	NH	August	www.pempicacemakers.com/
Border Wars	8/25 - 8/27	Beans Haney	913-244-4960	mhaney715@gmail.com	Parker	KS	August	freestaterangers.com

CLUB NAME	DATE	CONTACT	PHONE	EMAIL	CITY	ST	MONTH	WEB
SASS Wisconsin State Championship Fire In The Hills	8/26 - 8/27	Colonel Carbine	715-790-9959	garoth1961@gmail.com	Glenwood City	WI	August	www.wowsinc.org
Shootout at the Susquehanna	8/26 - 8/28	Jewels Cartwright	607-222-4228	rhtsty@stny.rr.com	Owego	NY	August	www.riogasporthmen.com
Wolverton Mountain PeaceKeepers 17th Annual Match "Lonesome Dove"	8/26 - 8/28	Evergreen Rose	360-901-5688	baughma@yahoo.com	Ariel	WA	August	www.wolvertonmtnpeacekeepers.com
SASS Michigan State Championship Wolverine Rangers Range War	9/2 - 9/4	Sinola Kid	734-612-0570	sinolakid@gmail.com	Kimball	MI	September	www.wolverinerangers.org
Cow Camp	9/2 - 9/4	Letort Lawman	717-249-5049	letordlawman@gmail.com	Ickesburg	PA	September	www.perrycountyregulators.com/
SASS Virginia State Championship Gunfight at the Double-C	9/2 - 9/4	Major B. S. Walker	804-307-2980	majorbswalker@gmail.com	Montpelier	VA	September	www.cavaliercowboys.org
RoughRider Roundup	9/2 - 9/4	Rod-Iron-Rip	701-223-3085	ripsroast@bis.midco.net	Moffit	ND	September	www.dakotaroughriders.com
Shoot'n in the Shade	9/2 - 9/4	Bulldog McGraw	501-337-9368	bulldogmcgraw@outlook.com	Hot Springs	AR	September	www.mvsaonline.com
The Branson Triple Classic	9/2 - 9/3	Stennett Kid	417-350-5271	martyhansen1964@att.net	Walnut Shade	MO	September	www.btc-sass.com/
Eagles Revenge	9/3 - 9/4	One Son of a Gun	231-676-0922	eagleville38@gmail.com	Central Lake	MI	September	www.eaglevillecowboys.org
SASS Kansas State Wild Bunch Championship	9/3 - 9/4	Cooncan	913-209-3836	cooncan.pcc@gmail.com	Lenexa	KS	September	www.powdercreekcowboys.com
SASS Nevada State Wild Bunch Championship	9/5 - 9/7	Irish Ike	775-250-4554	jeich455@charter.net	Fernley	NV	September	www.northernnevadacas.com
Southwest Showdown	9/8 - 9/10	Tomanator	580-847-2210	claytoma@gmail.com	Albany	OK	September	rrvcowpokes.weebly.com
Standoff at Smokey Point	9/9 - 9/11	Mudflat Mike	425-870-0193	tmperin@comcast.net	Arlington	WA	September	www.smokeypointdesperados.org
Shootout at Stoney Bottom	9/9 - 9/11	Badfinger Bodene	419-205-0114	badfinger66@gmail.com	Gibsonburg	OH	September	www.ourcowboys.org
SASS Missouri State Wild Bunch Championship Pershing's Own	9/9 - 9/11	Handlebar Scratch	417-865-5953	handlebar@thegenengraver.com	Walnut Shade	MO	September	bearcreekvolunteers.com/
SASS Maine State Championship Great Maine Gunfight	9/9 - 9/10	Tyler Tornado	207-272-7119	lylet@husson.edu	Berwick	ME	September	www.sfga.com
SASS Missouri Wild Bunch State Championships Pershing's Pursuit	9/9 - 9/11	Handlebar Scratch	417-865-5953	handlebar@thegenengraver.com	Walnut Shade	MO	September	bearcreekvolunteers.com/
SASS Southwest Territorial Wild Bunch Championship	9/9 - 9/11	Handlebar Scratch	417-865-5953	handlebar@thegenengraver.com	Walnut Shade	MO	September	bearcreekvolunteers.com/
Gunfight in Dixie	9/10 - 9/11	Buffalo Trace	901-831-3676	terry.bishop@shelby-sheriff.org	Lakeland	TN	September	www.msshooting.com
9th Annual Return of the Buffalo to the Plains	9/10 - 9/11	Sixty-Nine Cent Wizard	970-396-9010	sixty9centwizard@aol.com	Briggsdale	CO	September	www.briggsdalecountysshootists.com
Cheyenne Autumn	9/10 - 9/10	Eli Blue	806-729-5887	eli53766@yahoo.com	Kress	TX	September	N/A
Shoot and Toot	9/10 - 9/10	Gooch Hill Drifter	406-539-9400	ardebern@gmail.com	Logan	MT	September	sites.google.com/site/gallatinvalleyregulator2/
Gunfight along the Chisholm Trail	9/10 - 9/11	Monco	316-491-3249	danny38fp@gmail.com	Benton	KS	September	ctaga.com
SASS MIDWEST REGIONAL CHAMPIONSHIP Gunsmoke	9/14 - 9/17	Bronco Kate	507-269-2230	broncokate45@gmail.com	Morristown	MN	September	cedarvalleyvigilantes.com
SASS New York State Championship Heluwa Rukus	9/16 - 9/18	Feany Valentine	315-357-2352	gold_dog@frontiernet.net	Ballston Spa	NY	September	www.circlekeregulators.com/
Non Annual Annual BBQ Match	9/16 - 9/18	Pinto Being	970-270-4853	pschutz1@msn.com	Whitewater	CO	September	www.tmscba.com
Fall Fandango	9/16 - 9/18	Captain Jack Houston	505-463-6216	clnorfolk@msn.com	Albuquerque	NM	September	www.riogranderenegades.org
SASS Kansas Black Powder State Championship The Battle at Butterfield	9/16 - 9/18	Flint Hills Dawg	785-479-0416	dawgpownd@eaglecom.net	Chapman	KS	September	www.butterfieldgulch.com
Ambush at Canyon Walls	9/16 - 9/18	May B. Shecann	406-531-4116	johnny.and.may@gmail.com	Hamilton	MT	September	www.BitterrootBuckaroos.com
Northwest Territorial Shoot	9/16 - 9/17	Nels Gandy	503-953-5643	nelsgandy@gmail.com	Boise	ID	September	idahocowboyaction.org
Comin' At Cha	9/21 - 9/24	T-Bone Dooley	903-272-9283	tbonedooley@aol.com	Clarksville	TX	September	www.badlandsbar3.com
SASS Missouri State Championship Show-Me Shootout	9/22 - 9/24	Longshot John	417-299-7635	easymav12@yahoo.com	Marshfield	MO	September	www.so-mo-rangers.com
Shootout At Helldorado	9/22 - 9/25	Lead Nickel	707-391-5991	frednickel@comcast.net	Ukiah	CA	September	www.ukiahgunclub.com
SASS West Virginia State Championship Appalachian Showdown	9/23 - 9/25	Last Word	304-289-6098	lastword@cidlink.net	Largent	WV	September	www.wvcass.org
Big Sky State Games	9/23 - 9/24	Homestake Drifter	406-652-6158	ar129@aol.com	Billings	MT	September	https://www.mtpeacemakers.com/
Shootout at Shakey's Gulch	9/23 - 9/25	Justice D. Spencer	574-536-4010	jjdarrigan@msn.com	Bristol	IN	September	www.wolffsrowdyrangers.com/
Fall Round Up	9/23 - 9/25	Rootin Tootin	563-349-2273	prlucky299@aol.com	Milan	IL	September	www.willowairregulars.com
T-Town Shoot Out	9/24 - 9/24	Sheriff J. W. Hopkins	785-640-3742	sheriff.hopkins@hotmail.com	Topeka	KS	September	www.capitalcitycowboys.org
SASS Oklahoma State Championship Battle at the Crossroads	9/29 - 10/1	Scott Wayne	918-285-0543	mcac842565@aol.com	Cushing	OK	September	Lincolncountycowboys.com
SASS Southeast Regional Ambush at Cavern Cove	9/29 - 10/1	Buck D. Law	256-504-4366	don.carlton@arrowgraphics.net	Woodville	AL	September	www.northalabamaregulators.com
SASS Nevada State Championship Eldorado	9/30 - 10/1	Lady Glitter	702-429-4102	ladyofglitter@cox.net	Boulder City	NV	September	www.eldoradocowboys.com
Comanche Moon Shootout	10/1 - 10/1	Tumbleweed Dan	432-557-0860	dhagins421@suddenlink.net	Midland	TX	October	www.comanchetrailshootists.org/
Missouri/ Arkansas Border Wars	10/1 - 10/1	Ozark Captain	417-372-2993	ozarkcaptain@gmail.com	Mountain Home	AR	October	www.twinlakesgunclub.com
Rifleman's Holiday	10/1 - 10/2	Monty Rio	928-243-4471	bco173rd@yahoo.com	St. Johns	AZ	October	www.wmows.com
Huntsman World Senior Games	10/3 - 10/8	Bit Younger	435-239-4014	clark_poulton@q.com	Hurricane	UT	October	www.dixiedesperados.com
Buzzard Boil	10/7 - 10/9	Double Tap Taylor	860-384-0543	ljfisherman@yahoo.com	Coventry	CT	October	www.CTValleyBushwackers.com
Biggest Little Match	10/7 - 10/9	Pinto Annie	509-520-2789	pintoannie@cowboybullets.com	Dayton	WA	October	www.ccs shooting.com
Annual Charly Shoot	10/8 - 10/8	Colorado Smith	814-695-7064	adsmith0@yahoo.com	Holidaysburg	PA	October	www.pahcsa.com
SASS National Championship Land Run	10/8 - 10/16	Missouri Mae	405-517-8433	missourimae@gmail.com	Oklahoma City	OK	October	cowboy.okgunclub.org/
Peaceful End of Track at High Sierra	10/13 - 10/16	Grizzly Peak Jake	510-703-8064	trb94611@yahoo.com	Railroad Flat	CA	October	https://cagunslingers.com/
SASS New Jersey State Championship Purgatory in The Pines	10/14 - 10/16	El Diablo Gringo	973-662-0785	dave@servpro9326.com	Jackson	NJ	October	www.jacksonhollegang.com
SASS West Virginia State Wild Bunch Championship at Buffalo Flats XII	10/15 - 10/16	Eddie Rebel	304-397-6188	eccclark@suddenlink.net	Eleanor	WV	October	www.kanahavalleyregulators.com
SASS Louisiana State Championship Hot Lead in Deadwood	10/21 - 10/23	Doc Spudley	504-458-1898	docspudley@bellsouth.net	Serrento	LA	October	www.deadwoodmarshals.com/
October Suprise	10/22 - 10/22	Yukon Gal	910-988-0406	dldavis60@aol.com	Bunlevel	NC	October	www.facebook.com/groups/1177703212410628
SASS Arizona State Championship Bordertown	10/25 - 10/30	Quicksand	520-290-8599	pikcoyle@msn.com	Tombstone	AZ	October	www.bordertowncas.com
SASS North Carolina State Championship Uprising at Swearing Creek	11/3 - 11/5	Noah Fitz	828-851-1910	Noahfitz.ncci@yahoo.com	Salisbury	NC	November	SASSnccowboys.com
SASS Texas State Wild Bunch Championship	11/4 - 11/6	Col. Dusty Boddams	469-569-3322	jhurst@pvhome.com	Bowie	TX	November	www.facebook.com/groups/928402084279710/
SASS Bradshaw Mountain Reunion	11/12 - 11/12	Reverend Leadslinga	480-200-2986	reverend.leadslingsa@gmail.com	Phoenix	AZ	November	www.acsainc.com
Turkey Shoot	11/13 - 11/13	Silver Rings	970-240-0419	pckinco@yahoo.com	Montrose	CO	November	N/A
Turkey Shoot	11/19 - 11/19	Def Willie	979-220-1130	defwillie@suddenlink.net	North Zulch	TX	November	www.willowholecowboys.com/
Defend Old Fort Parker	11/19 - 11/20	Slowaz Molasses	254-366-2372	agomez8@hotmail.com	Groesbeck	TX	November	www.oldfortparkerpatriots.weebly.com/

Follow us on



Instagram

@singleactionshootingsociety

AND OTHER SOCIAL MEDIA



THE Cowboy CHRONICLE

SUBMISSION GUIDELINES

The Cowboy Chronicle welcomes and encourages submissions of articles and match reports from any and all readers.

Please submit articles in MS Word or something compatible. Open Office and Apple Pages (saved as MS Word) are also fine. A count of 500-800 words is a good target to shoot for, but shorter pieces are also fine. Match reports on larger events, like END of TRAIL, Winter Range, and Regional and Divisional matches may run 1000-1500 words if necessary. We will accept lengthier articles, but may choose to break them up into two or more parts to run in consecutive issues, or heavily edit them.

Please do not embed your photos in the Word document. They can be extracted for use in the *The Cowboy Chronicle*, but it can be a chore to do that. Instead, send your photos separately, in one or more emails, as attachments. Three to six photos per email usually works best. It's best to send JPEGs, but other formats are acceptable, and it's best to keep them at about 300 dpi and 3000 pixels (10 inches) on the short side. That size is

ideal and will allow us plenty of leeway when it comes to cropping and adjusting them for publication. Photos should be at least 1000 pixels on the short side to be used for publication. If you're unsure of the size of your pictures, or how to size them, send what you have and we'll adjust them and/or inform you if they're usable.

Usually, two to six photos are sufficient for an article, but we will consider using more for a "big" event, if provided. Photos need not have captions, but captions always make photos more interesting. Ideally, the caption would consist of one or two sentences that say something about the picture that is not obvious and/or is not implicit in the body of the article. "Sam making smoke" is a title but not a caption. "Sam, SASS #XXXXX, shooting his first black powder match; after much deliberation, he decided to give it a try and now he's hooked" is much better. A caption may also serve to let everyone know why the picture is worthy of being published in an international magazine.

Please use editor@sassnet.com for all article submissions.